

# Inline Mixed Flow Fans

# MXC Series



Energy (W) Efficient



Powerful



Low Noise



# Why KRUGER ?

KRUGER has been a leading innovator and manufacturer of residential, commercial and industrial fan application solutions across Asia since 1985. Today with a direct presence in over 18 regions throughout Asia; world class R&D and manufacturing facilities; KRUGER are able to offer their customers unparalleled service and support at a local level. Our customers place their trust in KRUGER.

## What is a

### KRUGER Mixed Flow fan ?

The **MXC Mixed Flow series** from KRUGER combines the benefit of a high airflow volume axial fan with the static pressure development of a centrifugal fan. This combination offers an optimised **energy efficient and low noise** solution for many commercial and industrial ventilation applications.

## Why use a

### KRUGER MXC Mixed Flow fan ?



**High efficiency performance**



**Energy (W) saving**



**Lower operating costs**

Peak total operating efficiencies of +77% with AMCA FEI levels >1.1



**Low noise**



**Optimised dynamic balancing and vibration control**



**Increased product life**

KRUGER MXC offer one of the lowest noise / cfm in the industry.



**Compact size**



**Smaller ducts**



**Lower installation costs**

MXC Series offers a more compact sized extract or supply ventilation solution to comparable axial or centrifugal fans.



**Versatile design**



**Suitable for many ventilation applications**



**Installation friendly**

- Suitable for the extract (or supply) of clean, grease laden or high temperature (up to F400) airstreams.
- The below table shows the sound power (LwA) and the total efficiency of the KRUGER MXC mixed flow fan versus comparable tubular centrifugal and vane axial fans.
- The MXC Series generates the lowest sound levels and highest fan total efficiency across a wide range of operating points.

Performance	Fan Size	Total Efficiency			Sound Power (LwA)		
		Mixed Flow	Vane Axial	Tu bular Centrifugal	Mixed Flow	Vane Axial	Tu bular Centrifugal
30,000 CMH@500 Pa	1000	75%	70%	57%	91	106	93
30,000 CMH@ 750 Pa	1000	77%	68%	58%	93	103	98
30,000 CMH@ 1000 Pa	1000	76%	62%	61%	95	106	100

Fan size comparisons based on closed tube diameters.

# Typical Ventilation

## Applications

### OFFICE BUILDING

**SMOKE SPILL**  
(STAIRWAY/CORRIDOR)



### APARTMENT/CONDOMINIUM

**SMOKE SPILL**  
(STAIRWAY/CORRIDOR)



### COMMERCIAL BUILDING

VENTILATION SUPPLY  
/EXHAUST

### COMMERCIAL AREA

KITCHEN EXHAUST  
/SUPPLY FOR RESTAURANT  
IN COMMERCIAL

### UNDERGROUND PARKING

SUPPLY FAN/EXHAUST (SMOKE SPILL)



## Smoke Spill Fan

# Summary of key

## standard MXC Series specifications

- A** Nominal fan diameters sizes from 315-2000 mm.
- B** Airflow and static pressure performance of up to 230,000 CMH and 2,000 Pa.
- C Airstream operating temperatures**
  - Clean air standard ventilation applications -20°C to +55°C.
  - Commercial kitchen (grease laden air) applications up to +80 °C /176°F.
  - High temperature smoke spill applications (MXC-D) up to 400°C/2hrs certified.
- D Extended operating life**  
Sealed bearings are designed for  $L_{10} > 75,000$  operating hours at maximum speed. Extended life construction with  $L_{10} > 200,000$  operating hours is available upon request. Vibration balanced to G2.5 in accordance with ISO14694/AMCA 204 standards.
- E Materials and Coatings**  
All MXC casing and parts are manufactured from galvanized steel (size 315-1120) and finished with a zinc primer and tough polyester coating finish (size 1250-2000). The polyester coating finish is salt-spray rated up to 1,000 hours in accordance with ASTM B117 testing standards. Suitable for both indoor and outdoor environments.

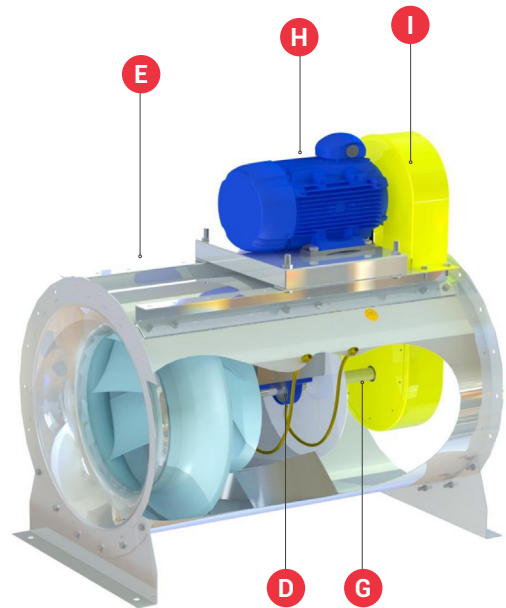

## F Certifications



Kruger Ventilation Industries Asia Co., Ltd certifies that the MXC Series and MXC-Bi Series shown herein are licensed to bear the AMCA seal. The ratings shown are based on tests and procedures performed in accordance with AMCA Publication 211 and AMCA Publication 311 and comply with the requirements of the AMCA Certified Ratings Program.



Certified for high-temperature performance (up to 400°C / 2 hours) in accordance with EN12101-3 standard, by globally renowned third-party testing and certification organizations, Applus and TÜV SÜD.

Class	Temperature (°C)	Minimum functioning period (minutes)
F <sub>1</sub> 250	250	120
F300	300	60
F <sub>3</sub> 300	300	120
F400	400	120



MXC Fan Testing at the APPLUS Test Laboratory in Asturias, Spain

- G High Precision Shafts (Belt Drive)**  
All belt drive shafts are manufactured from C45-grade steel and high precision G6 tolerance (ISO286-2) to minimize vibration and extend service life.
- H High Efficiency KRUGER Motors**  
All MXC Series fans are supplied with a wide variety of 3-phase AC, and PM, Standard and High Temperature rated motors. Optional 1-phase and EC motors are available upon request. Please consult your local KRUGER distributor for availability.
- I Safety Features**  
All belt-drive MXC models include a robust wire safety belt guard as standard. Optional inlet and outlet safety guards are available upon request.

# MXC Bifurcated Design

## What is

### bifurcated design ?

The bifurcated design MXC Series, MXC-Bi keeps the motor outside the airstream, protecting it from hot, grease-laden air.

This allows a direct driven fan to handle temperatures up to +100°C, ensuring the insulation Class F motor protection, durability, and reliable operation in kitchen exhaust application.

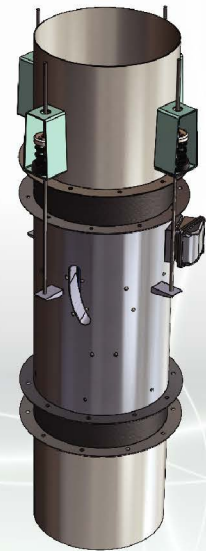
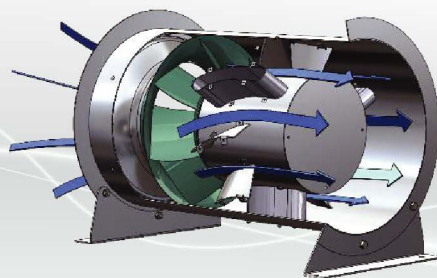
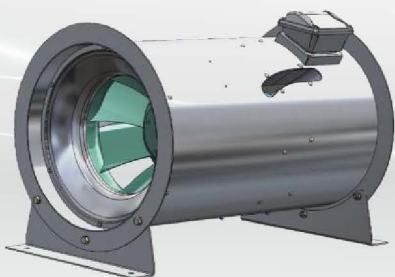

## Why use

### bifurcated design ?

#### 1. Cost-Efficient and Optimized Longevity

The bifurcated fan design, featuring a Class F motor positioned outside the hot air flow, not only ensures an extended service life but also facilitates shorter delivery lead times. This arrangement eliminates the traditional pulley and belt system, reducing the need for routine maintenance. Consequently, this design not only enhances the durability and reliability of the system but also results in considerable savings in operational costs.

#### 2. Space-Efficient and Flexible Design

The MXC-Bi features a direct drive system that allows for vertical or horizontal installation directly in ductwork, eliminating the need for complex transitions. Suitable for continuous operation in tight spaces, it efficiently handles temperatures up to +100°C.

#### 3. Energy saving

The MXC-Bi fan design achieves up to 73% total fan efficiency.

#### Illustrative Energy Saving Example

Model	Fan Duty		Driving method	Control ventilation	Abs Power (kW)	Power Consumption (kW)	Electric Consumption (kWh/Day)	Thailand Electric Charges (USD / Unit)	Daily Operating Cost (USD)	Monthly Operating Cost (USD)	Estimated Energy Saving (%)
	Q (cms)	Ps (Pa)									
BSB 315	0.71	250	Belt Driven	Typical ventilation	0.34	0.47	6.53	0.15	0.99	29.70	-
MXC-Bi 355			Direct Driven	Demand Control (DCV)	0.32	0.40	3.11		0.47	14.10	52%

Note:  
The above calculation is an illustrative example based on assumed operating conditions, electricity charges, and ventilation profile. Actual energy savings will vary depending on system design, operating hours, airflow requirements, and local electricity charges.

#### 4. Compliant with International Standards for Safety

The MXC-Bi fan, designed to meet key international safety and performance requirements for restaurant exhaust applications, including leak resistance and grease-laden air operation.

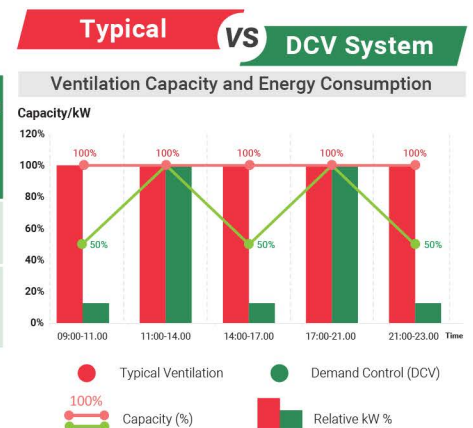

## MXC-Bi Series

### (Kitchen Exhaust) Specifications

 <b>Nominal Fan Diameter:</b>	355 - 1000 mm
 <b>Airflow Range:</b>	2000 CMH - 50,000 CMH
 <b>Static Pressure:</b>	200 - 1,800 Pa
 <b>Operating Temperature:</b>	Up to +100°C for grease-laden air
 <b>Ambient temperature:</b>	50°C / 120°F maximum (refer to typical installation figure)
 <b>Motor Insulation:</b>	Class F, inverter-compatible
 <b>Casing material:</b>	Welded bifurcated casing in high grade Carbon steel material

## Typical

### Installation

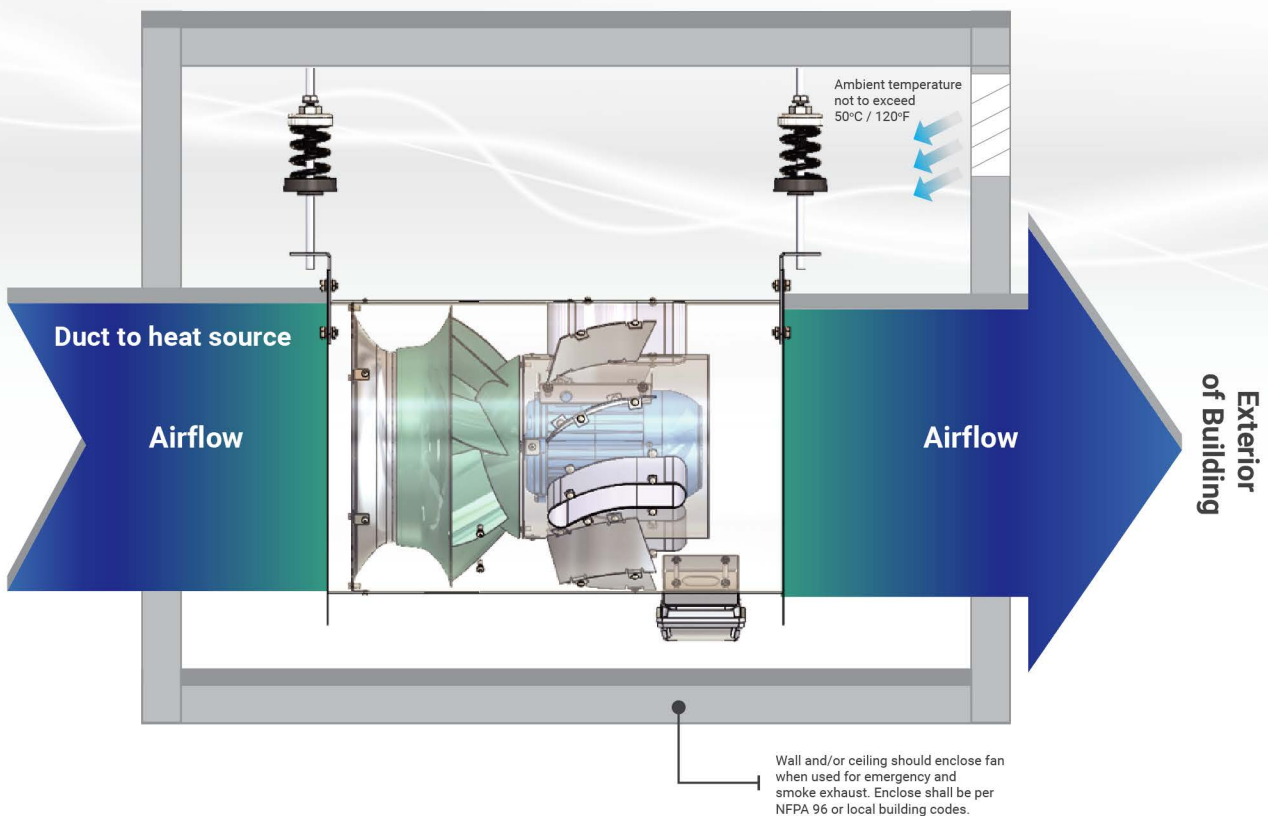

## Options and

### Accessories

- a** Inlet and outlet duct connection flanges to connect circular duct to MXC flanges.
- b** Circular flexible duct connectors, both standard and high temperature variations (up to F400).
- c** Inlet and outlet safety guards.
- d** Belt cover isolates drive sets from airstream and protection from rotating pulleys and belts.
- e** Casing access door for easy of cleaning of fan internals.
- f** Vibration isolator mounts for floor or ceiling mounted installations.
- g** Extended lubrication lines (Belt Drive) for bearing maintenance.
- h** A drain coupling can be attached to the bottom of housing.
- i** Special coatings for specialist corrosion application protection.
- j** Spark resistance construction, per AMCA Standard 99.

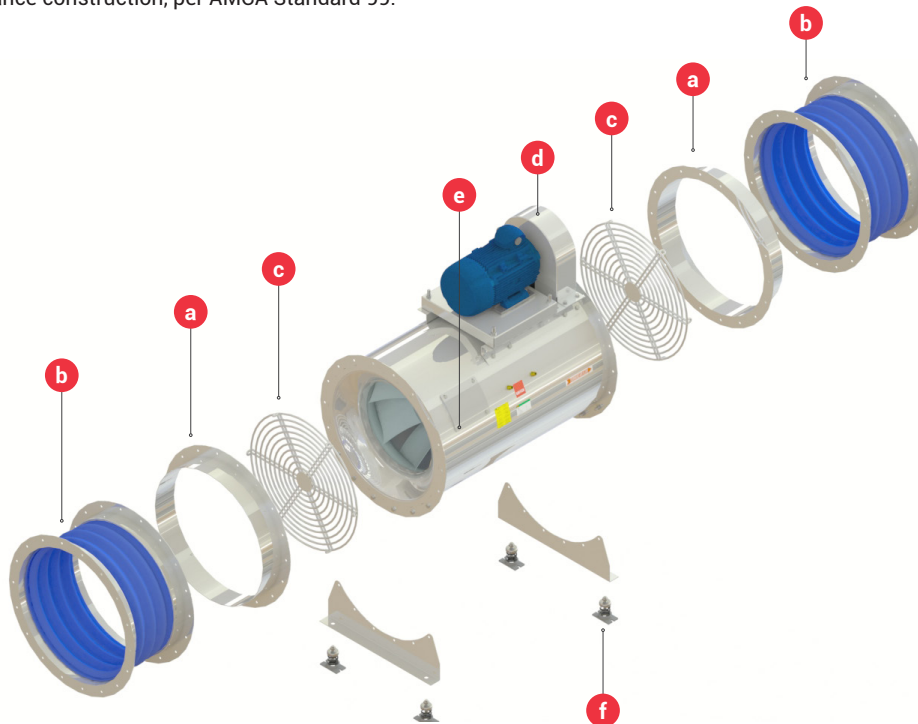

## Installation and

### Mounting

All MXC Series models can be mounted in either horizontal or vertical orientation. All models include provision (fixing locations) for floor or ceiling mounting. For belt drive units, the orientation of the belt-pulley and motor can be changed in the field to suit the installation.

CEILING

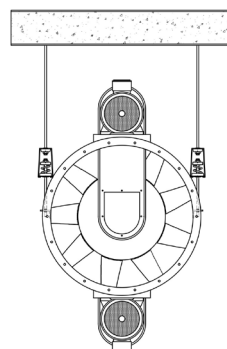
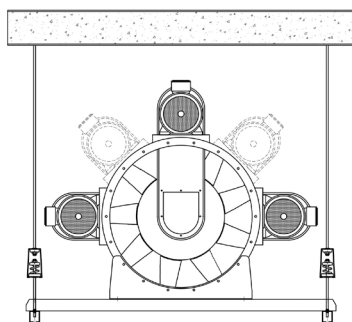

FLOOR

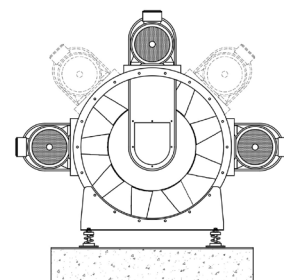

## Model number

nonmenclature

### MXC 1000 - D - N

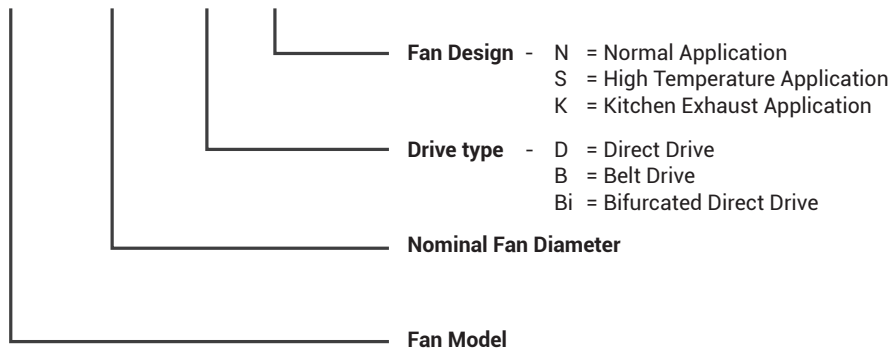

## Dimensions

- Direct drive and Bifurcated models

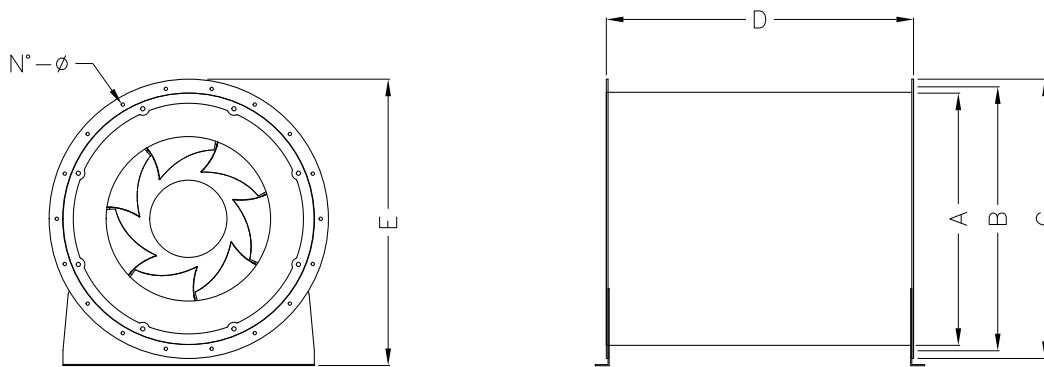

Model	A	B	C	D		E	N°	Ø	Weight* (kg)		Max Motor Frame Size*
				MXC-D	MXC-Bi				MXC-D	MXC-Bi	
355	355	395	435	560	560	455	8	10	25	27	71
400	400	440	480	630	630	502	12	10	33	36	80
450	450	490	530	630	630	553	12	10	37	40	90
500	500	540	580	710	710	608	12	10	49	53	100
560	560	605	660	800	800	680	12	10	63	68	112
630	630	675	730	900	900	805	12	10	75	83	132
710	710	755	810	1000	1000	837	18	12	124	137	132
800	800	845	900	1000	1100	926	18	12	172	189	160
900	900	945	1000	1100	1200	1026	18	12	215	237	180
1000	1000	1050	1100	1250	1350	1130	24	12	245	270	200
1120	1120	1186	1250	1400	-	1230	24	12	369	-	225
1250	1250	1315	1380	1400	-	1412	24	12	554	-	225
1400	1400	1465	1530	1600	-	1562	32	14	831	-	250
1600	1600	1663	1730	1800	-	1790	32	14	1084	-	280
1800	1800	1856	1930	2240	-	2005	32	14	1818	-	315
2000	2000	2073	2130	2240	-	2220	32	14	2072	-	315

\* Weight without motor

\*\* Please consult KRUGER for motor frame size other than specified

All dimension in mm.

## Dimensions

- Belt drive models

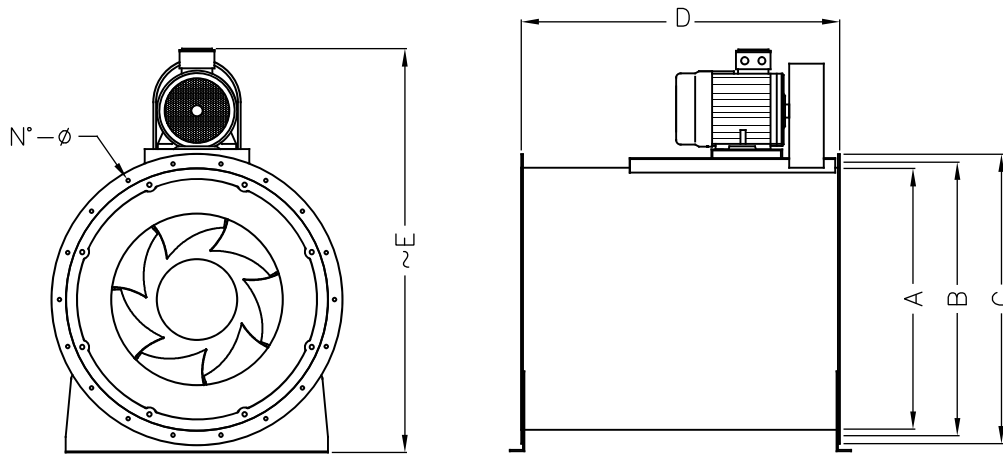

Model	A	B	C	D	E	N°	Ø	Weight* (kg)	Max Motor Frame Size**	Moment of Inertia of Wheel (kgm <sup>2</sup> )
315	315	355	395	500	600	8	10	34	90	0.023
355	355	395	435	560	650	8	10	44	100	0.040
400	400	440	480	630	720	12	10	53	112	0.065
450	450	490	530	630	765	12	10	63	112	0.102
500	500	540	580	710	890	12	10	80	112	0.190
560	560	605	660	800	990	12	10	102	132	0.315
630	630	675	730	900	1065	12	10	115	160	0.525
710	710	755	810	1000	1245	18	12	162	160	0.961
800	800	845	900	1000	1256	18	12	202	160	1.75
900	900	945	1000	1100	1395	18	12	243	180	3.17
1000	1000	1050	1100	1250	1515	24	12	298	200	4.98
1120	1120	1186	1250	1400	1665	24	12	424	225	7.60
1250	1250	1315	1380	1400	1845	24	12	615	225	14.23
1400	1400	1465	1530	1600	2120	32	14	960	250	23.93
1600	1600	1663	1730	1800	2445	32	14	1264	280	39.8
1800	1800	1856	1930	2240	2675	32	14	2002	315	75.4
2000	2000	2073	2130	2240	3005	32	14	2380	315	119.5

\* Weight without motor

\*\* Please consult KRUGER for motor frame size other than specified

All dimension in mm.

# Accessories

## Dimensions

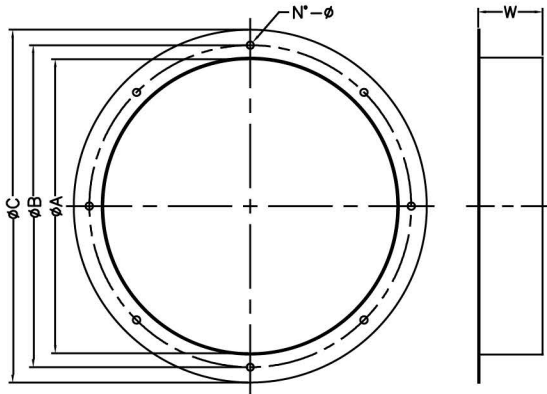

Inlet and Outlet Flanges

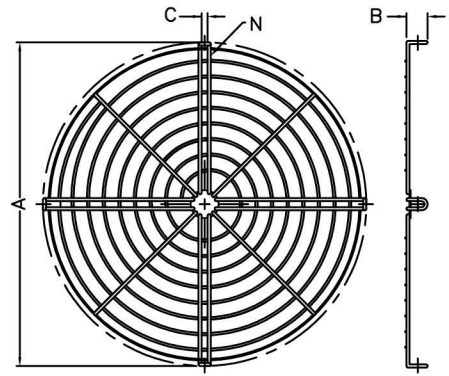

Inlet and Outlet Protection Nets

Model	A	B	C	W	N'	Ø
315	315	355	395	65	8	10
355	355	395	435	65	8	10
400	400	440	480	65	12	10
450	450	490	530	65	12	10
500	500	540	580	65	12	10
560	560	605	660	65	12	10
630	630	675	730	65	12	10
710	710	755	810	75	18	12
800	800	845	900	75	18	12
900	900	945	1000	75	18	12
1000	1000	1050	1100	75	18	12
1120	1120	1185	1250	85	24	12
1250	1250	1315	1380	85	24	12
1400	1400	1465	1530	85	32	14
1600	1600	1663	1730	85	32	14
1800	1800	1856	1930	95	32	14
2000	2000	2073	2130	95	32	14

Model	A	B	C	N'
315	313	25	10	4
355	353	25	10	4
400	398	25	10	4
450	448	25	10	4
500	498	25	10	4
560	558	25	10	4
630	628	25	10	4
710	708	25	10	6
800	798	25	10	6
900	898	25	10	6
1000	998	25	10	8
1120	1118	25	10	8
1250	1248	25	10	8
1400	1398	25	10	8
1600	1598	25	10	8
1800	1798	25	10	8
2000	1998	25	10	8

All dimension in mm.

# Accessories

## Dimensions

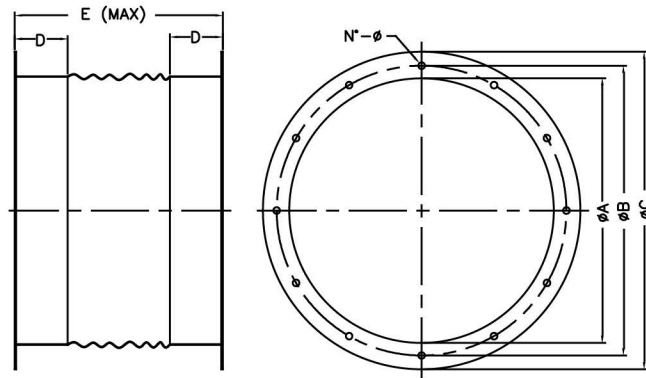

Flexible Duct

Model	A	B	C	D	E	N'	Ø
315	315	355	395	40	220	8	10
355	355	395	435	40	220	8	10
400	400	440	480	40	220	12	10
450	450	490	530	40	220	12	10
500	500	540	580	40	220	12	10
560	560	605	660	40	220	12	10
630	630	675	730	40	220	12	10
710	710	755	810	40	220	18	12
800	800	845	900	40	220	18	12
900	900	945	1000	40	220	18	12
1000	1000	1050	1100	40	220	18	12
1120	1120	1185	1250	40	220	24	12
1250	1250	1315	1380	40	220	24	12
1400	1400	1465	1530	40	220	32	14
1600	1600	1663	1730	40	220	32	14
1800	1800	1856	1930	40	220	32	14
2000	2000	2073	2130	40	220	32	14

All dimension in mm.

# Example of Selection

## MXC 1000 Selection

**Air Volume**  $Q = 32115 \text{ m}^3/\text{h}$   
**Outlet Velocity**  $V = 11.36 \text{ m/s}$   
**Dynamic Pressure**  $P_d = 77 \text{ Pa}$   
**Total Pressure**  $P_t = 823 \text{ Pa}$   
**Fan Speed**  $N = 1255 \text{ rpm}$   
**Absorbed Power**  $W = 9.52 \text{ kW}$   
**Total Efficiency**  $\eta = 77.1\%$   
**Sound Power Level**  $L_w(A) = 94 \text{ dB(A)}$

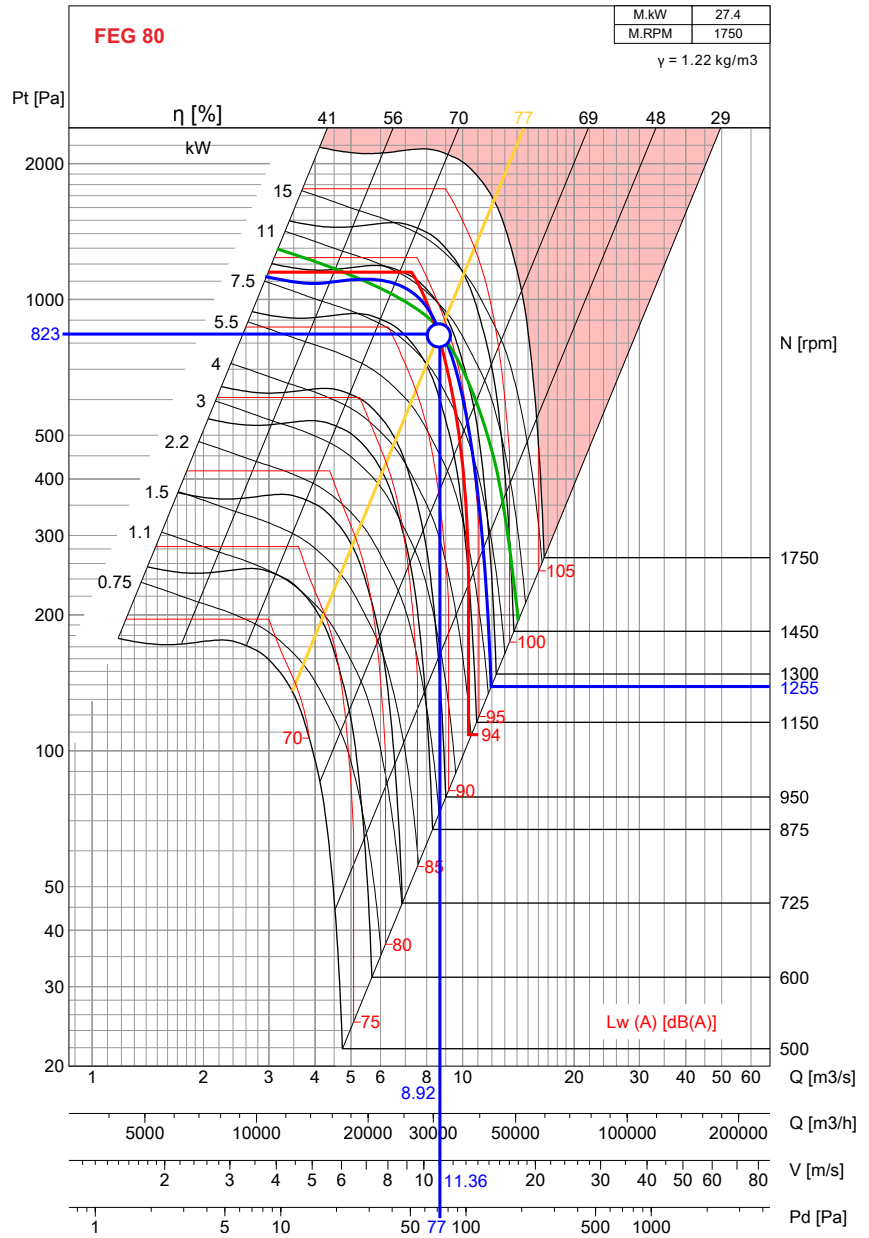

\* Performance certified is for Installation type D - Ducted inlet, Ducted outlet. Performance ratings do not include the effects of appurtenances (belt cover). Power rating kW does not include transmission losses.  
 \* The A-weighted sound ratings shown have been calculated per AMCA International Standard 301. Values shown are for inlet  $L_w A$  sound power levels for installation type D - Ducted inlet, Ducted outlet. Ratings include the effects of duct end correction.

# MXC 315

## Selection

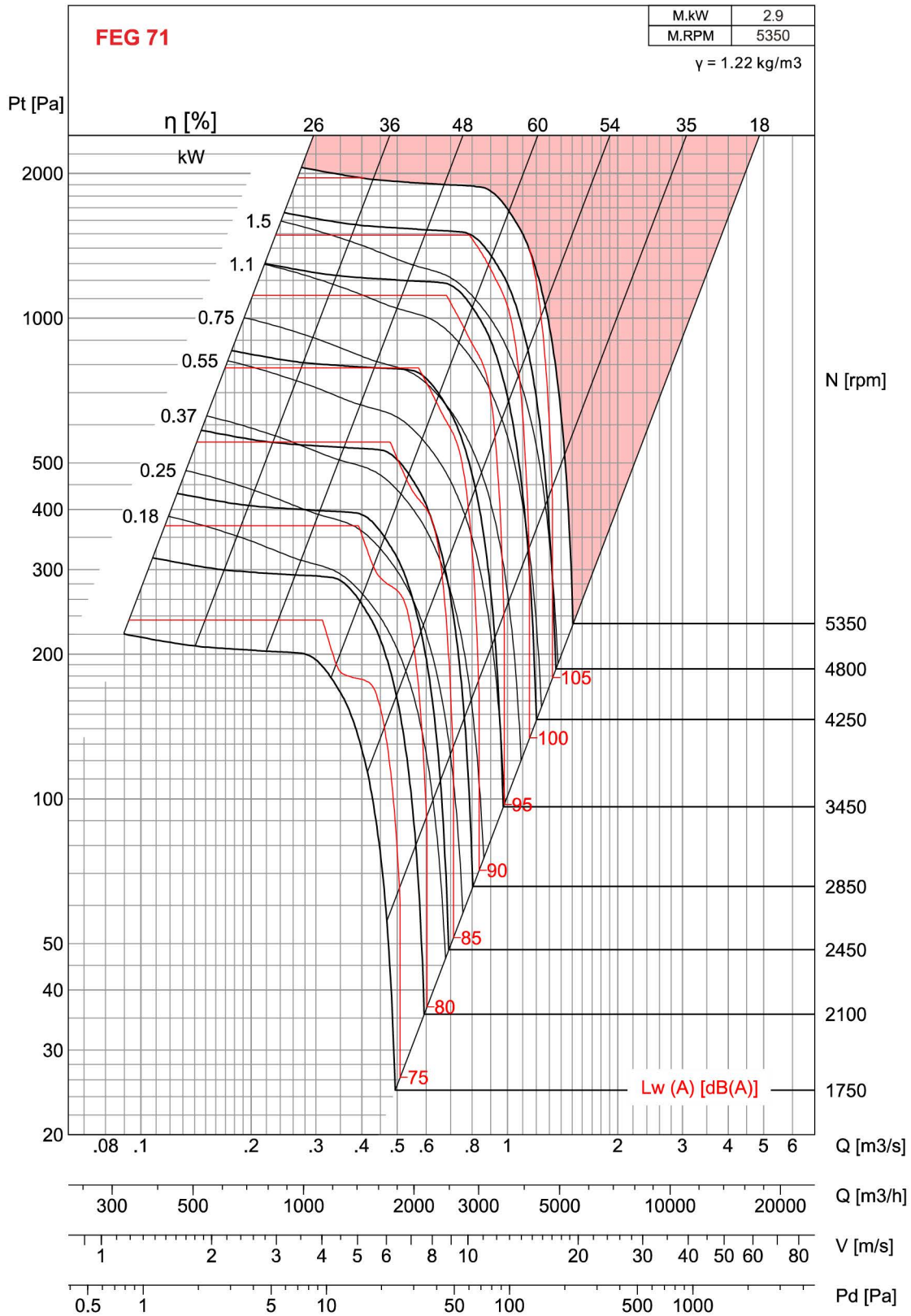

- Performance certified is for Installation type D - Ducted inlet, Ducted outlet. Performance ratings do not include the effects of appurtenances (belt cover). Power rating kW does not include transmission losses.
- The A-weighted sound ratings shown have been calculated per AMCA International Standard 301. Values shown are for inlet Lw A sound power levels for installation type D - Ducted inlet, Ducted outlet. Ratings include the effects of duct end correction.

# MXC 355

## Selection

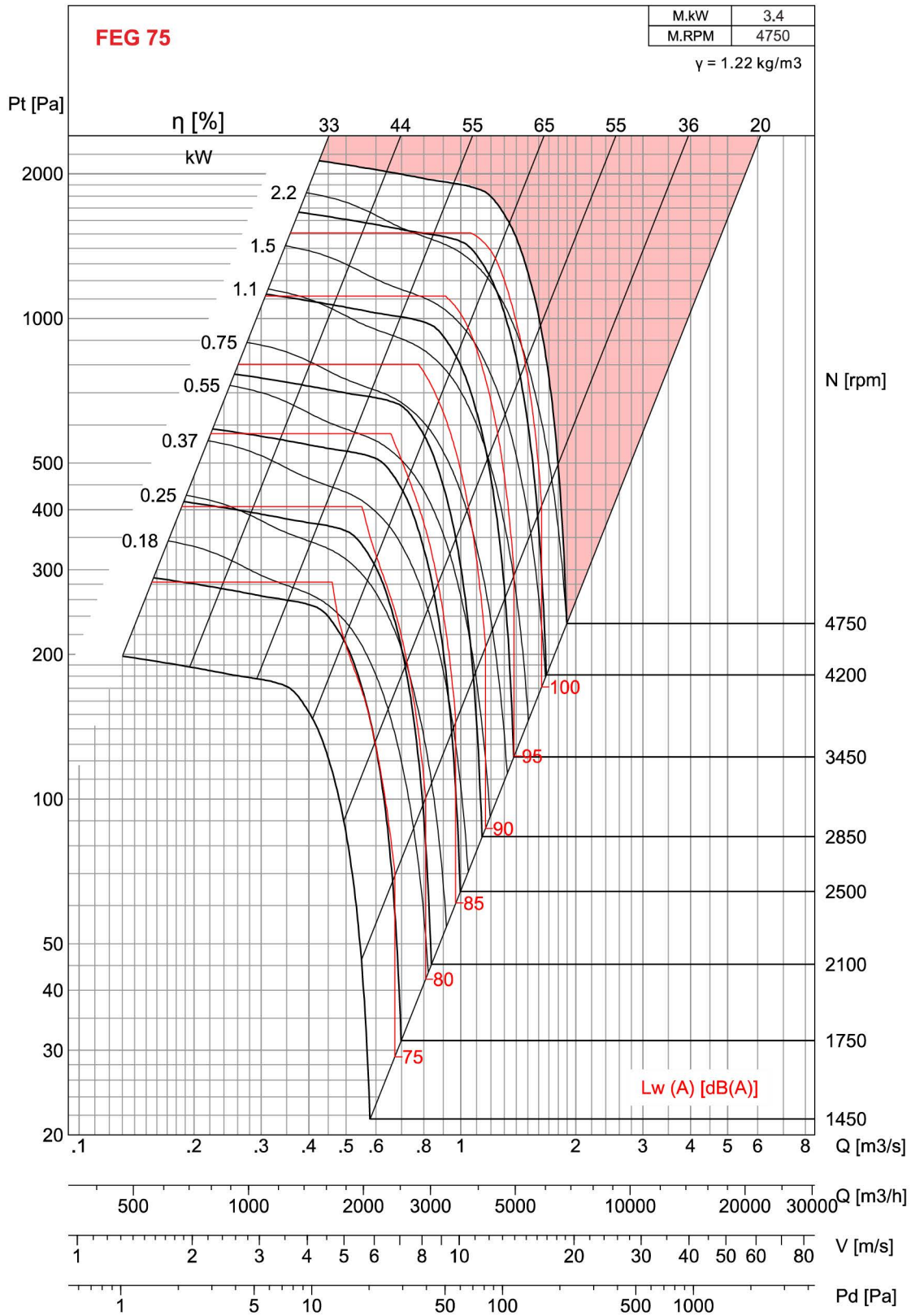

- Performance certified is for Installation type D - Ducted inlet, Ducted outlet. Performance ratings do not include the effects of appurtenances (belt cover). Power rating kW does not include transmission losses.
- The A-weighted sound ratings shown have been calculated per AMCA International Standard 301. Values shown are for inlet Lw A sound power levels for installation type D - Ducted inlet, Ducted outlet. Ratings include the effects of duct end correction.

# MXC 400

## Selection

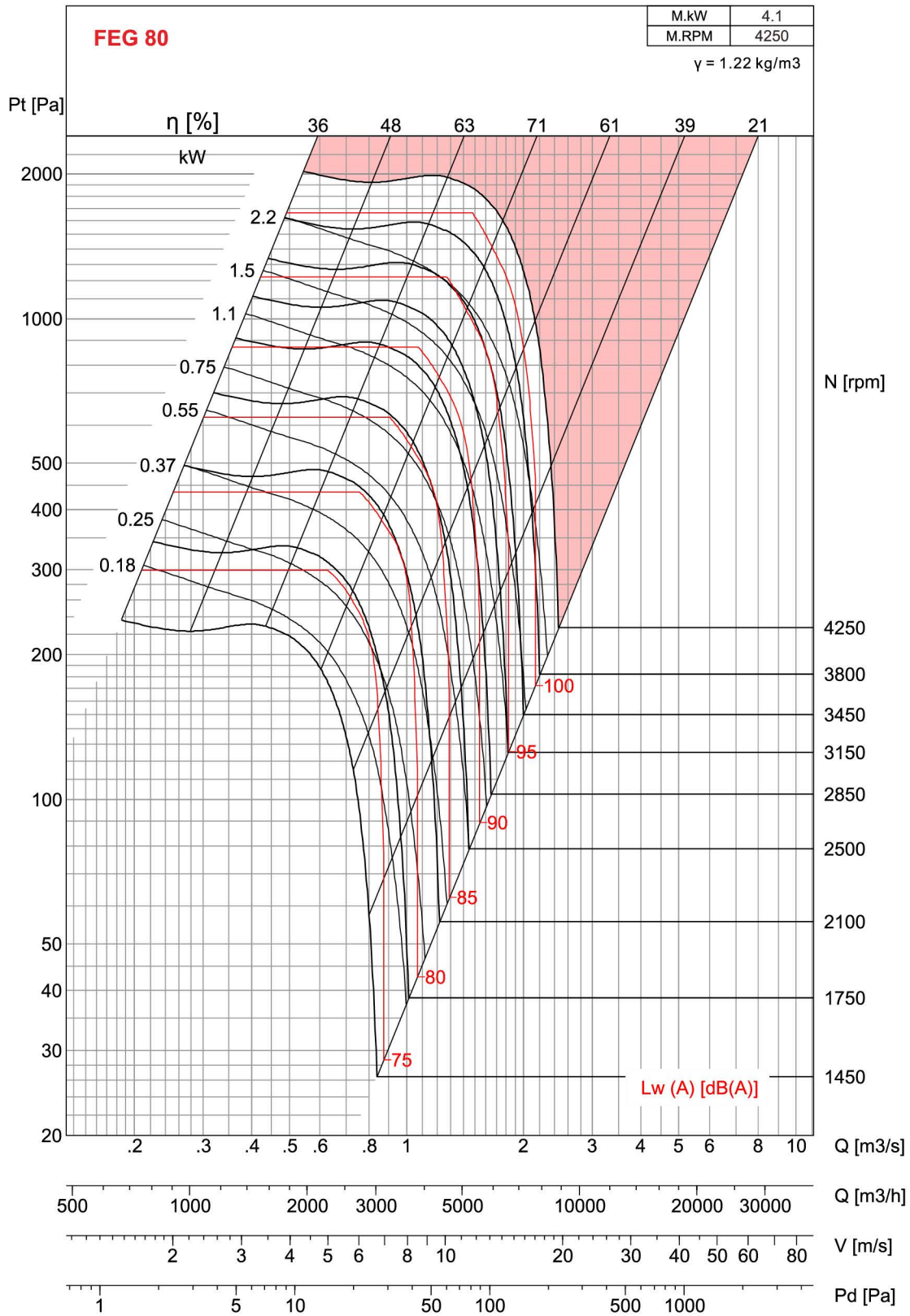

- Performance certified is for Installation type D - Ducted inlet, Ducted outlet. Performance ratings do not include the effects of appurtenances (belt cover). Power rating kW does not include transmission losses.
- The A-weighted sound ratings shown have been calculated per AMCA International Standard 301. Values shown are for inlet Lw A sound power levels for installation type D - Ducted inlet, Ducted outlet. Ratings include the effects of duct end correction.

# MXC 450

## Selection

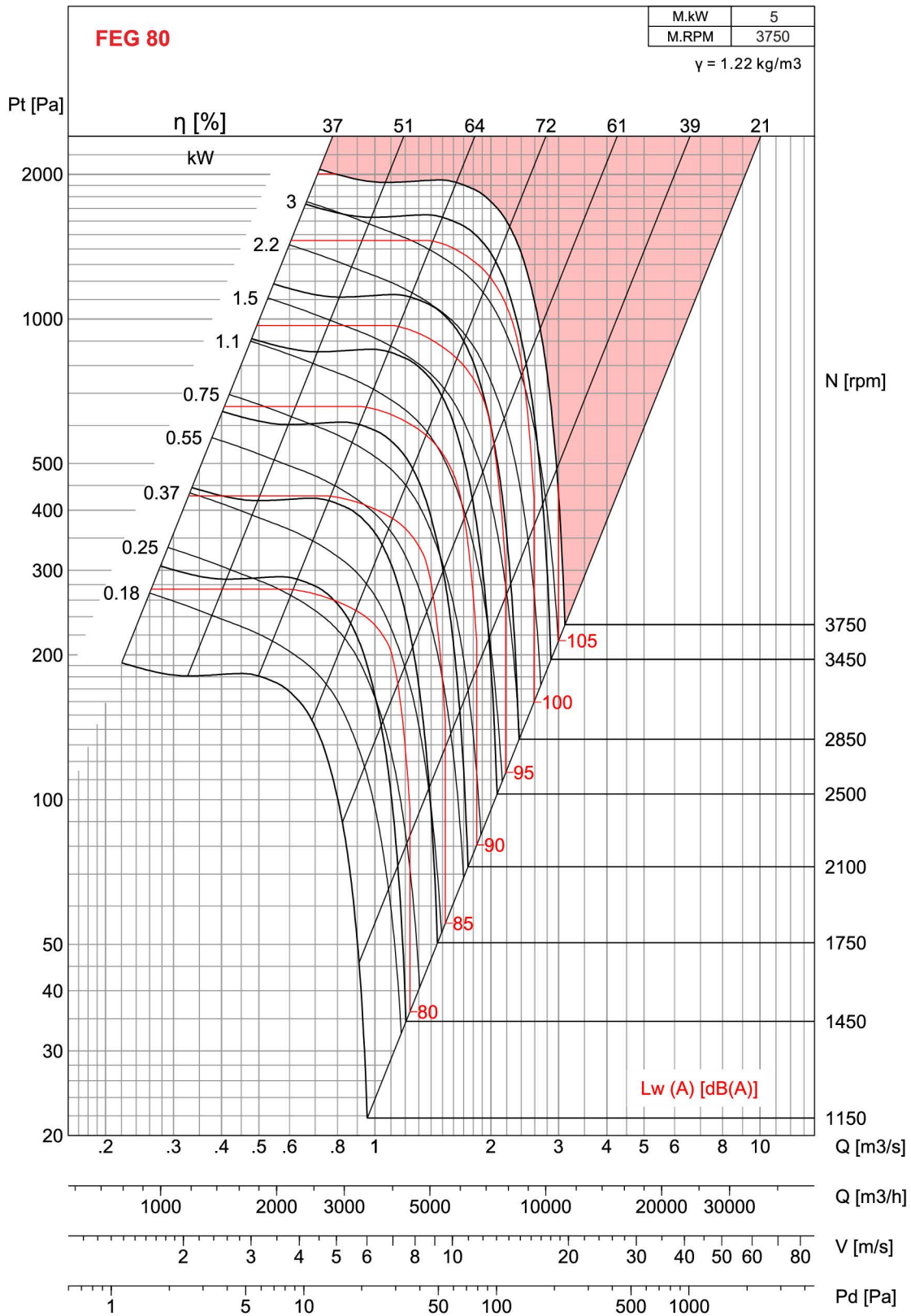

- Performance certified is for Installation type D - Ducted inlet, Ducted outlet. Performance ratings do not include the effects of appurtenances (belt cover). Power rating kW does not include transmission losses.
- The A-weighted sound ratings shown have been calculated per AMCA International Standard 301. Values shown are for inlet Lw A sound power levels for installation type D - Ducted inlet, Ducted outlet. Ratings include the effects of duct end correction.

# MXC 500

## Selection

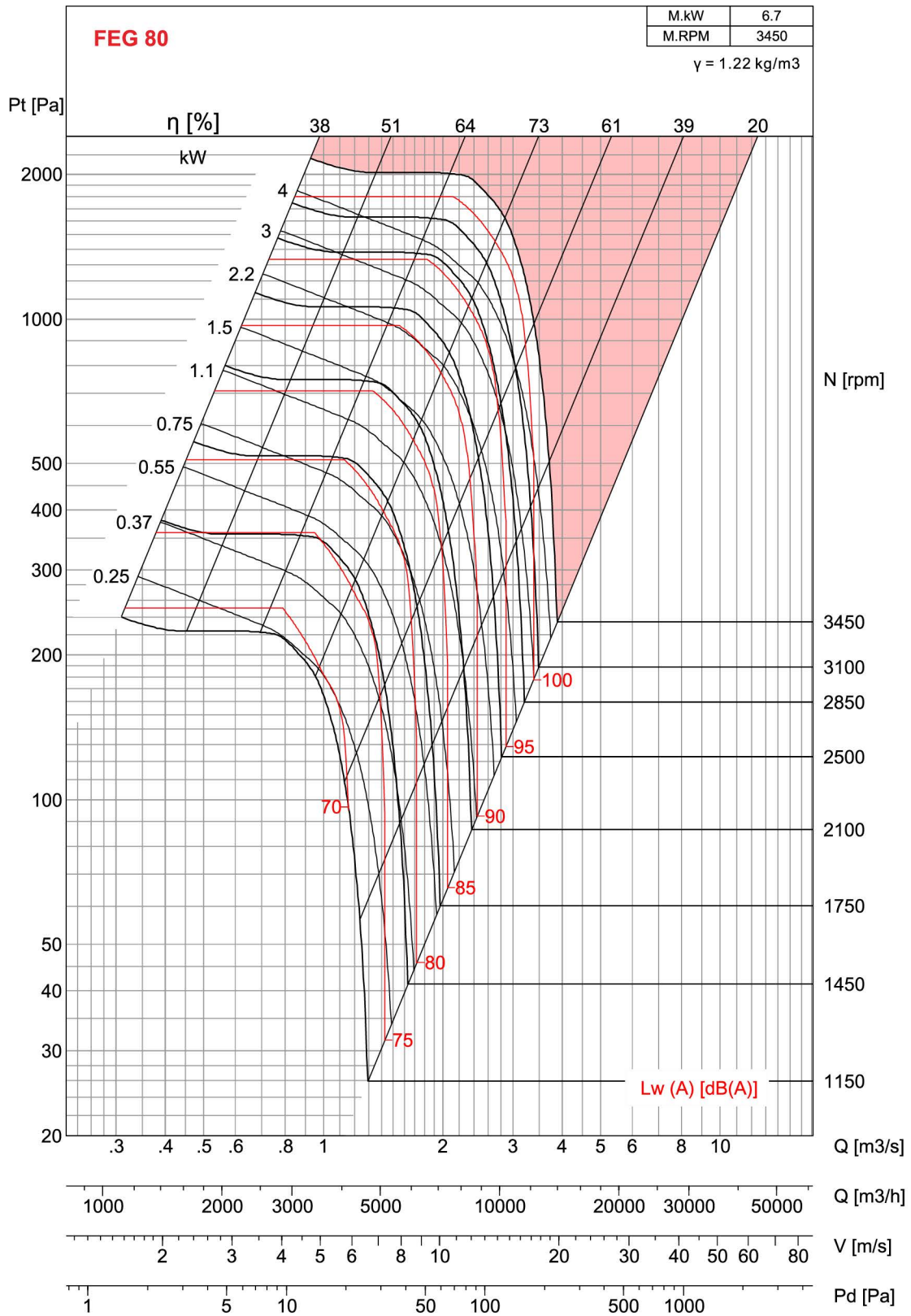

- Performance certified is for Installation type D - Ducted inlet, Ducted outlet. Performance ratings do not include the effects of appurtenances (belt cover). Power rating kW does not include transmission losses.
- The A-weighted sound ratings shown have been calculated per AMCA International Standard 301. Values shown are for inlet Lwi A sound power levels for installation type D - Ducted inlet, Ducted outlet. Ratings include the effects of duct end correction.

# MXC 560

## Selection

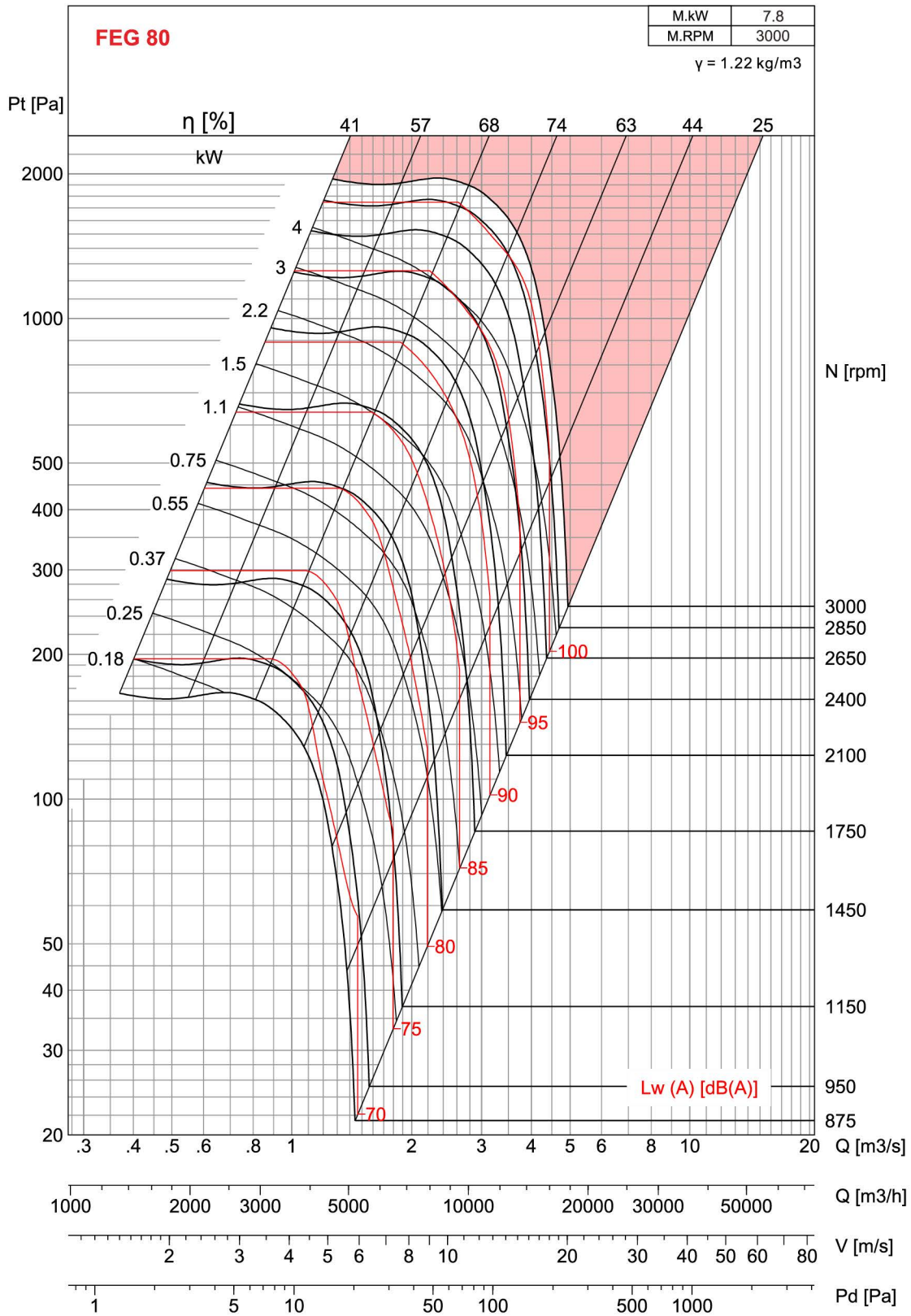

- Performance certified is for Installation type D - Ducted inlet, Ducted outlet. Performance ratings do not include the effects of appurtenances (belt cover). Power rating kW does not include transmission losses.
- The A-weighted sound ratings shown have been calculated per AMCA International Standard 301. Values shown are for inlet Lwi A sound power levels for installation type D - Ducted inlet, Ducted outlet. Ratings include the effects of duct end correction.

# MXC 630

## Selection

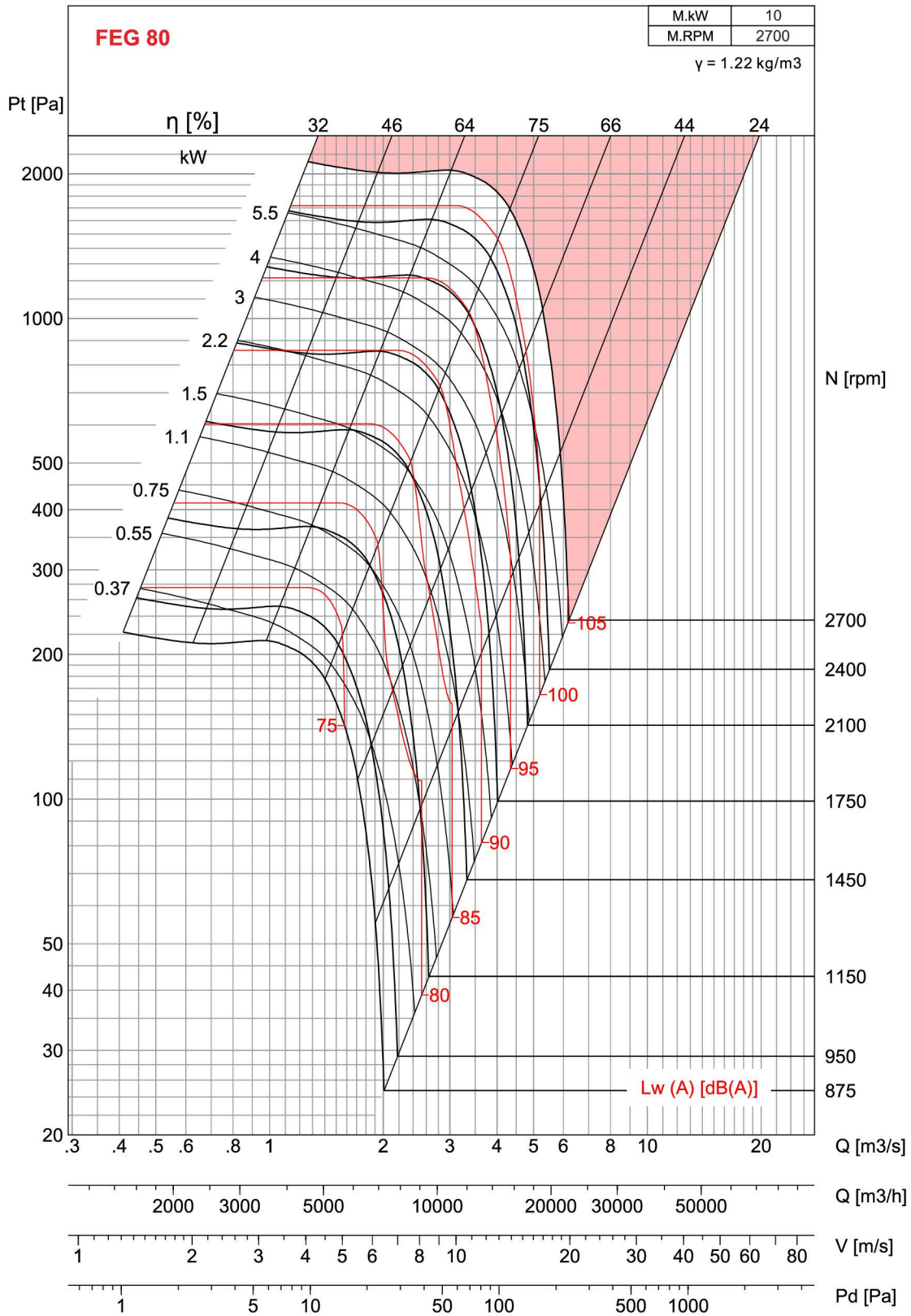

- Performance certified is for Installation type D - Ducted inlet, Ducted outlet. Performance ratings do not include the effects of appurtenances (belt cover). Power rating kW does not include transmission losses.
- The A-weighted sound ratings shown have been calculated per AMCA International Standard 301. Values shown are for inlet Lwi A sound power levels for installation type D - Ducted inlet, Ducted outlet. Ratings include the effects of duct end correction.

# MXC 710

## Selection

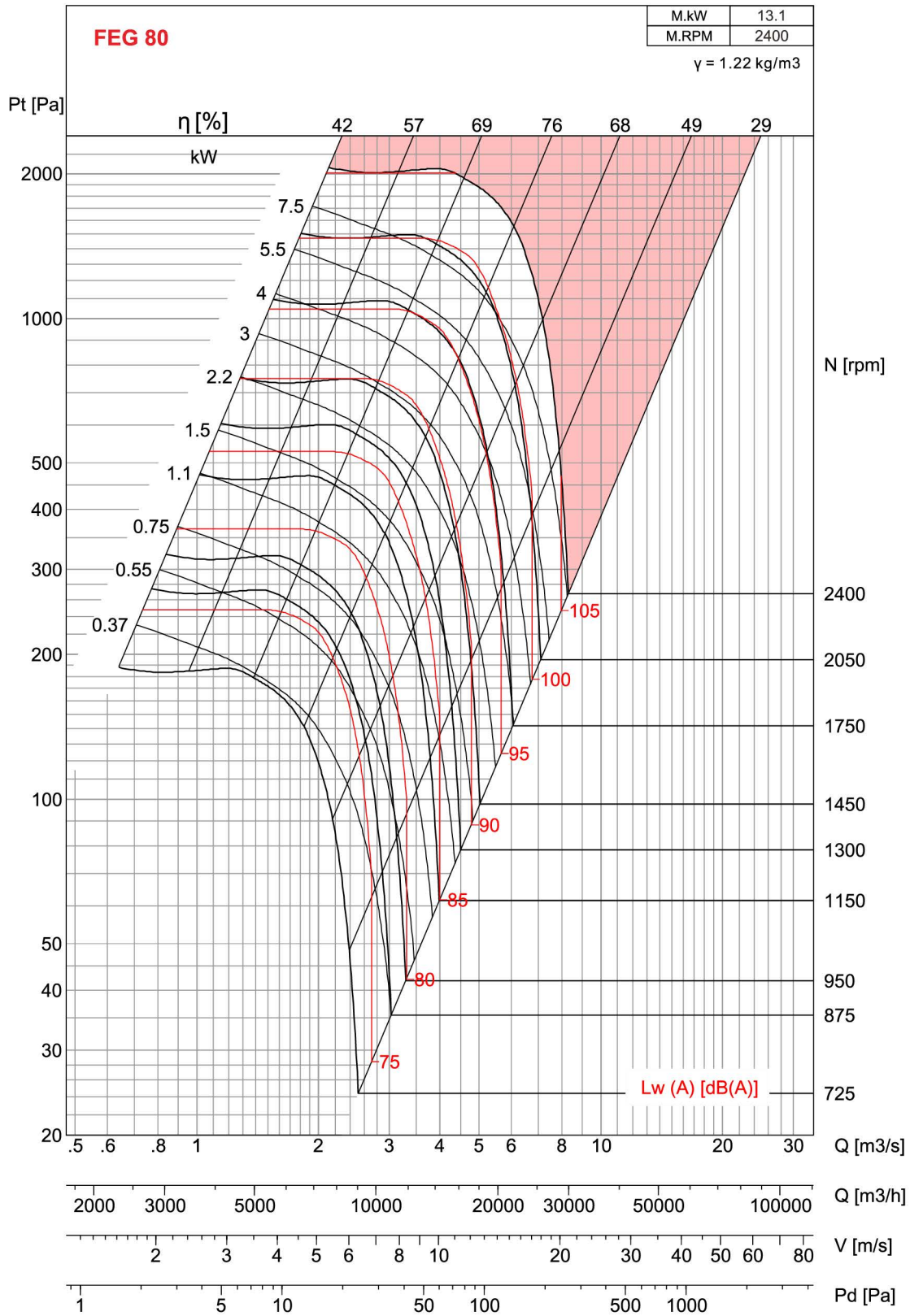

- Performance certified is for Installation type D - Ducted inlet, Ducted outlet. Performance ratings do not include the effects of appurtenances (belt cover). Power rating kW does not include transmission losses.
- The A-weighted sound ratings shown have been calculated per AMCA International Standard 301. Values shown are for inlet Lw A sound power levels for installation type D - Ducted inlet, Ducted outlet. Ratings include the effects of duct end correction.

# MXC 800

## Selection

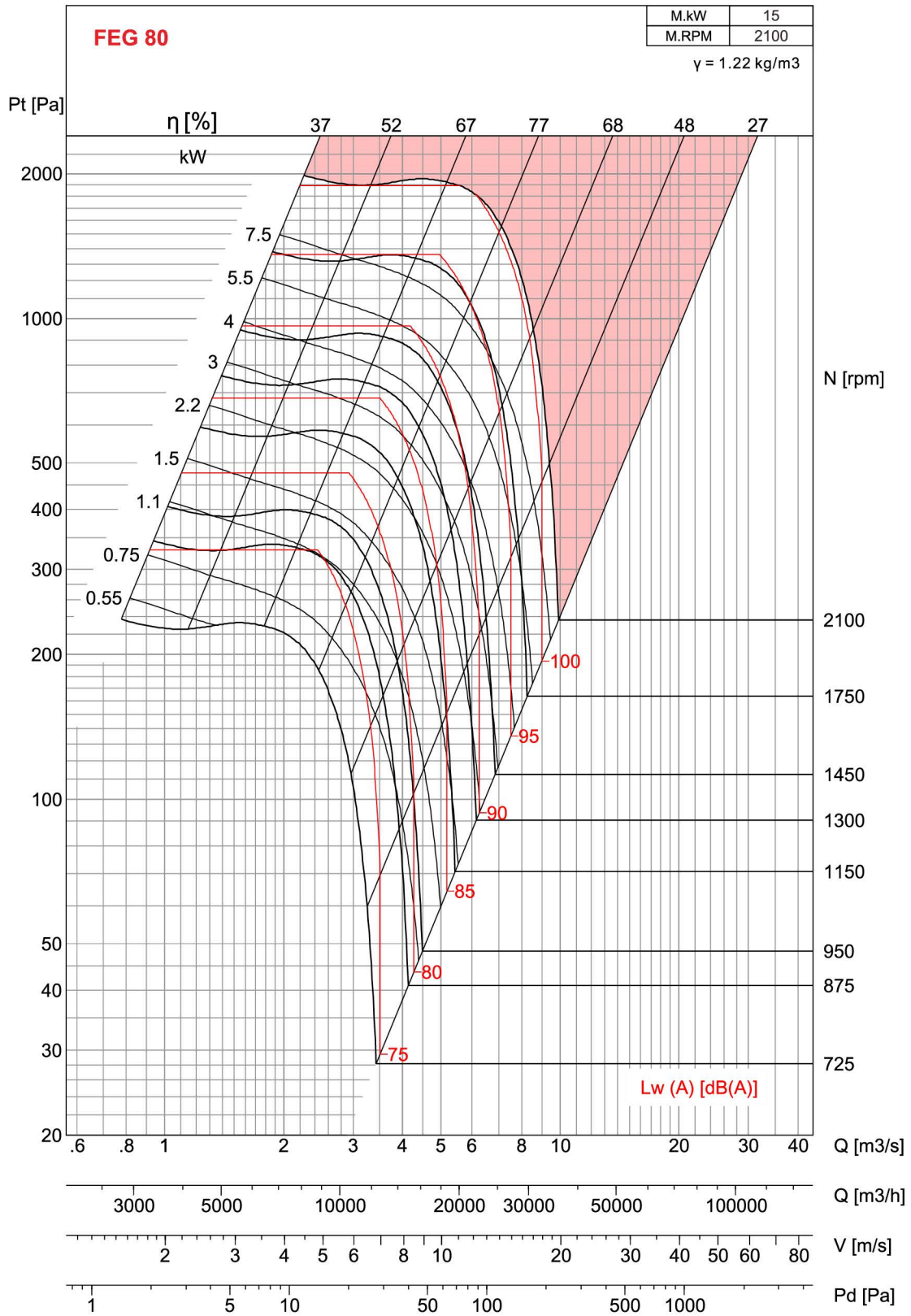

- Performance certified is for Installation type D - Ducted inlet, Ducted outlet. Performance ratings do not include the effects of appurtenances (belt cover). Power rating kW does not include transmission losses.
- The A-weighted sound ratings shown have been calculated per AMCA International Standard 301. Values shown are for Inlet Lw A sound power levels for installation type D - Ducted inlet, Ducted outlet. Ratings include the effects of duct end correction.

# MXC 900

## Selection

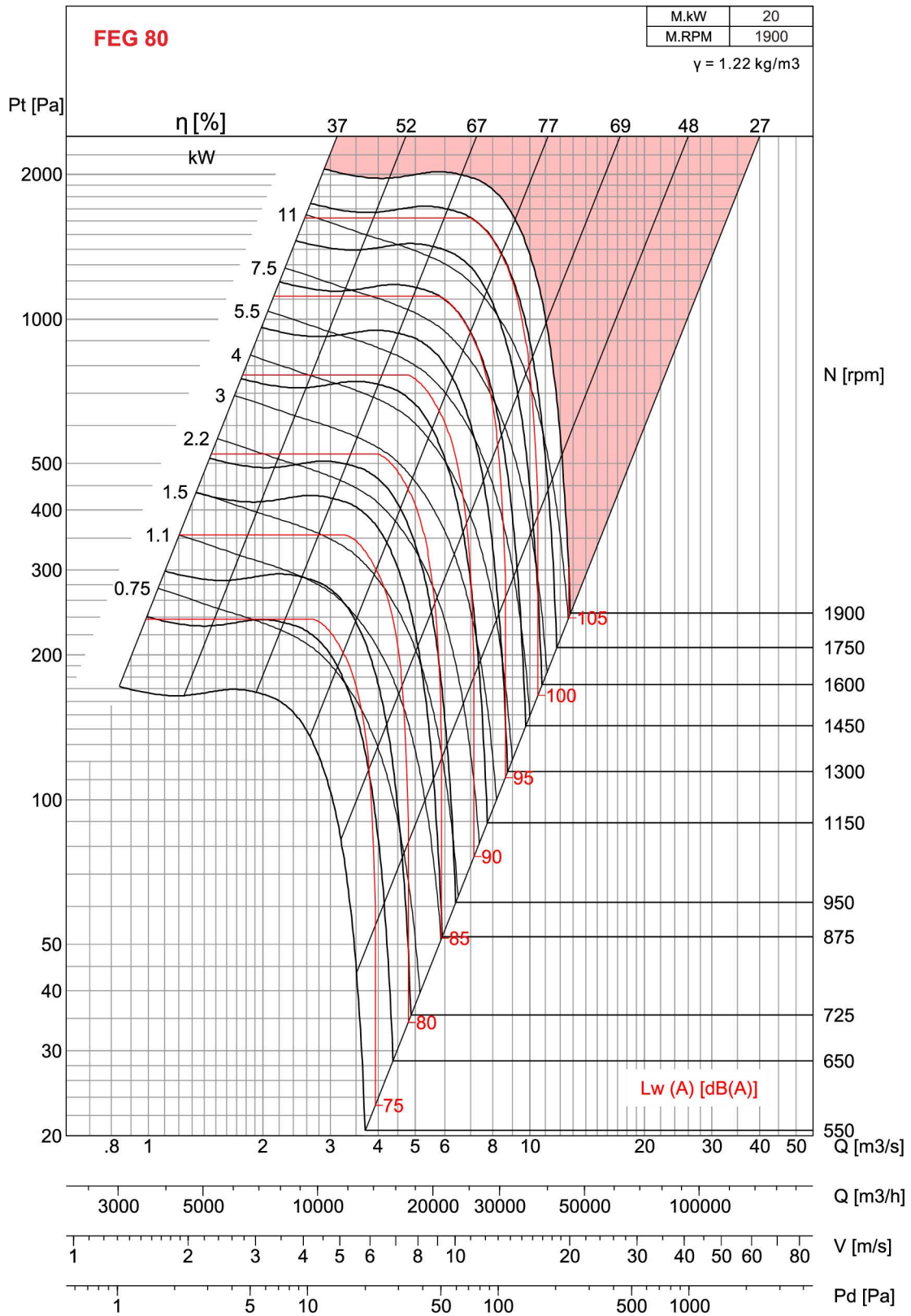

- Performance certified is for Installation type D - Ducted inlet, Ducted outlet. Performance ratings do not include the effects of appurtenances (belt cover). Power rating kW does not include transmission losses.
- The A-weighted sound ratings shown have been calculated per AMCA International Standard 301. Values shown are for inlet Lwi A sound power levels for installation type D - Ducted inlet, Ducted outlet. Ratings include the effects of duct end correction.

# MXC 1000

## Selection

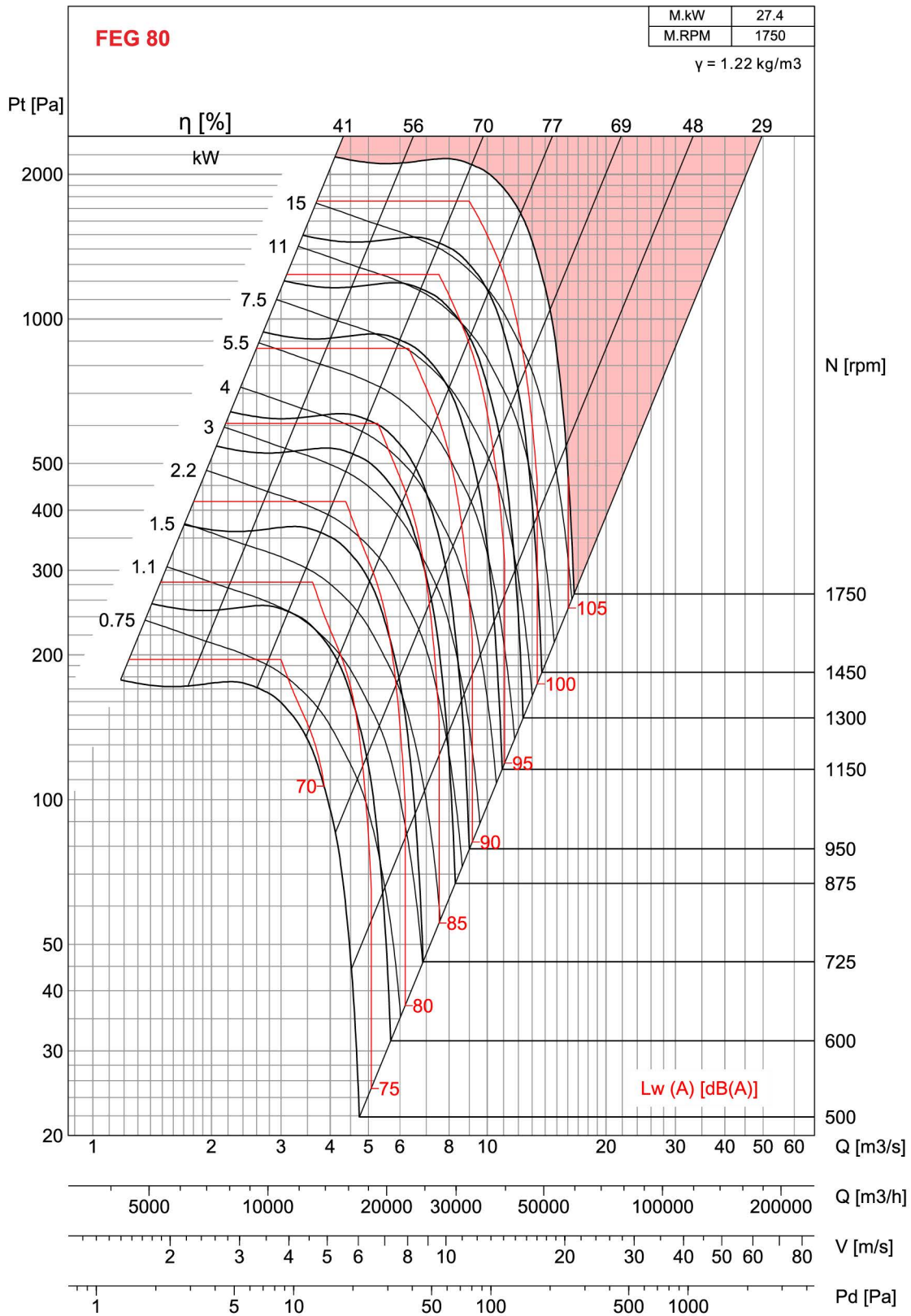

- Performance certified is for Installation type D - Ducted inlet, Ducted outlet. Performance ratings do not include the effects of appurtenances (belt cover). Power rating kW does not include transmission losses.
- The A-weighted sound ratings shown have been calculated per AMCA International Standard 301. Values shown are for inlet Lwi A sound power levels for installation type D - Ducted inlet, Ducted outlet. Ratings include the effects of duct end correction.

# MXC 1120

## Selection

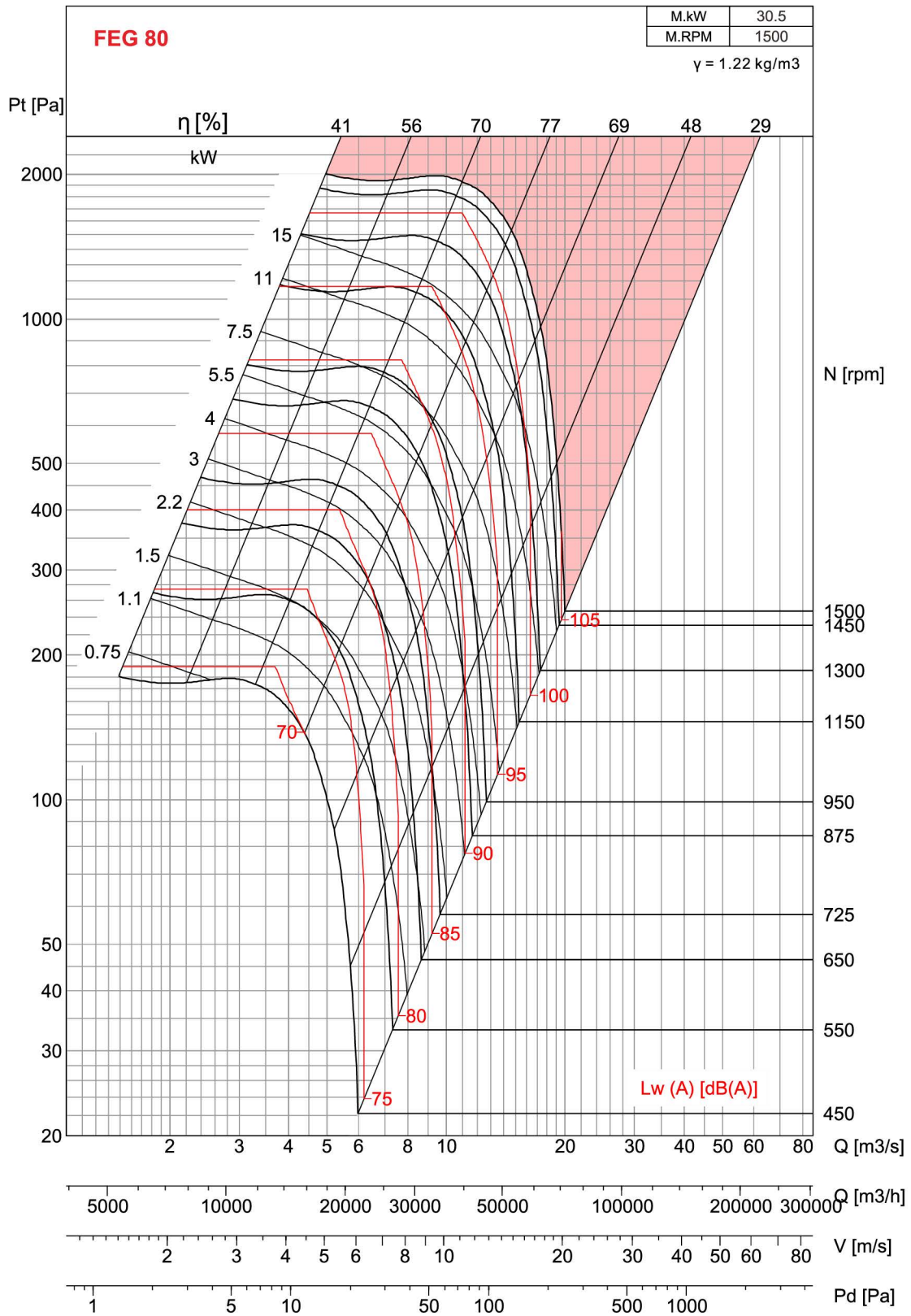

- Performance certified is for Installation type D - Ducted inlet, Ducted outlet. Performance ratings do not include the effects of appurtenances (belt cover). Power rating kW does not include transmission losses.
- The A-weighted sound ratings shown have been calculated per AMCA International Standard 301. Values shown are for inlet Lw A sound power levels for installation type D - Ducted inlet, Ducted outlet. Ratings include the effects of duct end correction.

# MXC 1250

## Selection

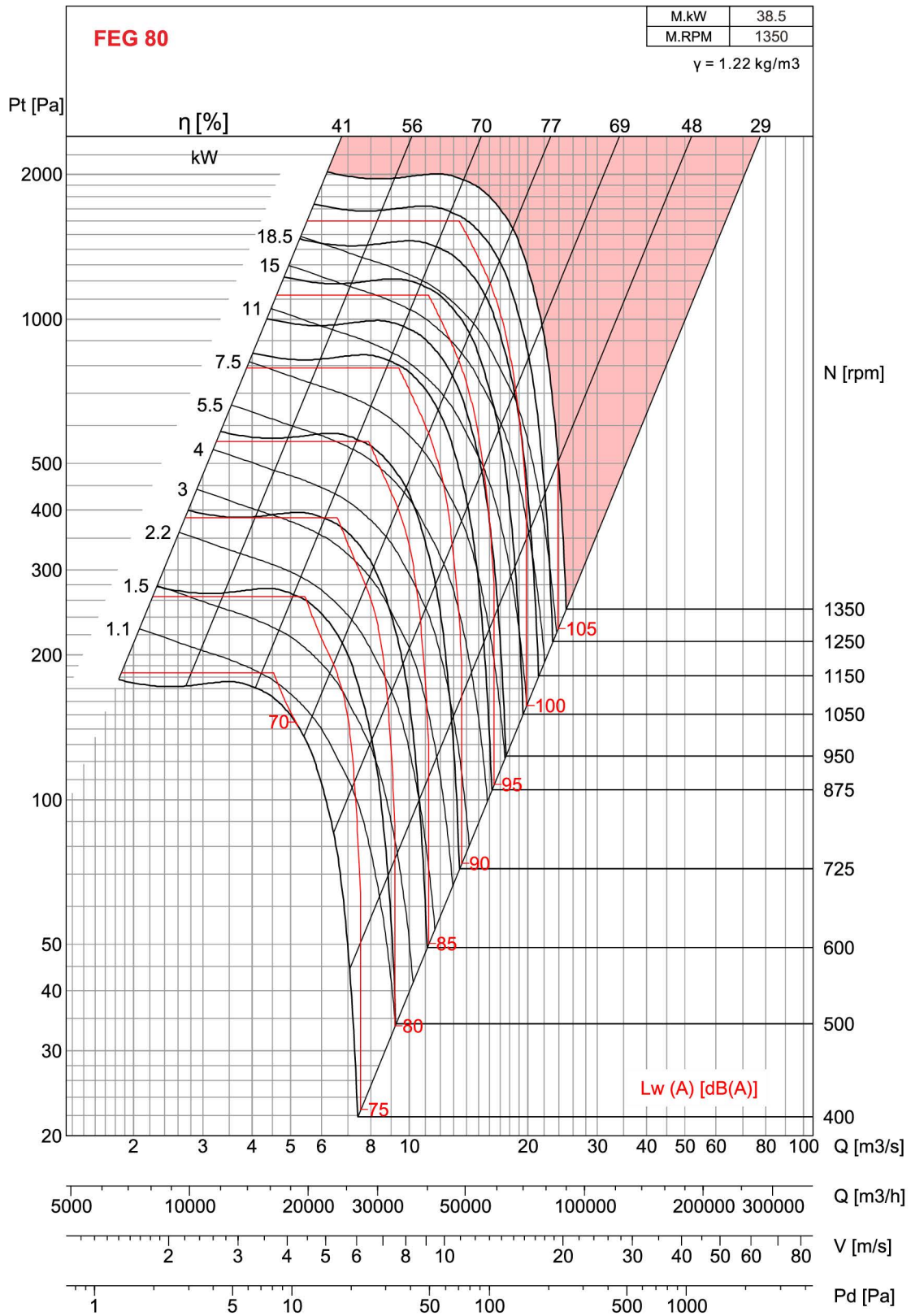

- Performance certified is for Installation type D - Ducted inlet, Ducted outlet. Performance ratings do not include the effects of appurtenances (belt cover). Power rating kW does not include transmission losses.
- The A-weighted sound ratings shown have been calculated per AMCA International Standard 301. Values shown are for inlet Lwi A sound power levels for installation type D - Ducted inlet, Ducted outlet. Ratings include the effects of duct end correction.

# MXC 1400

## Selection

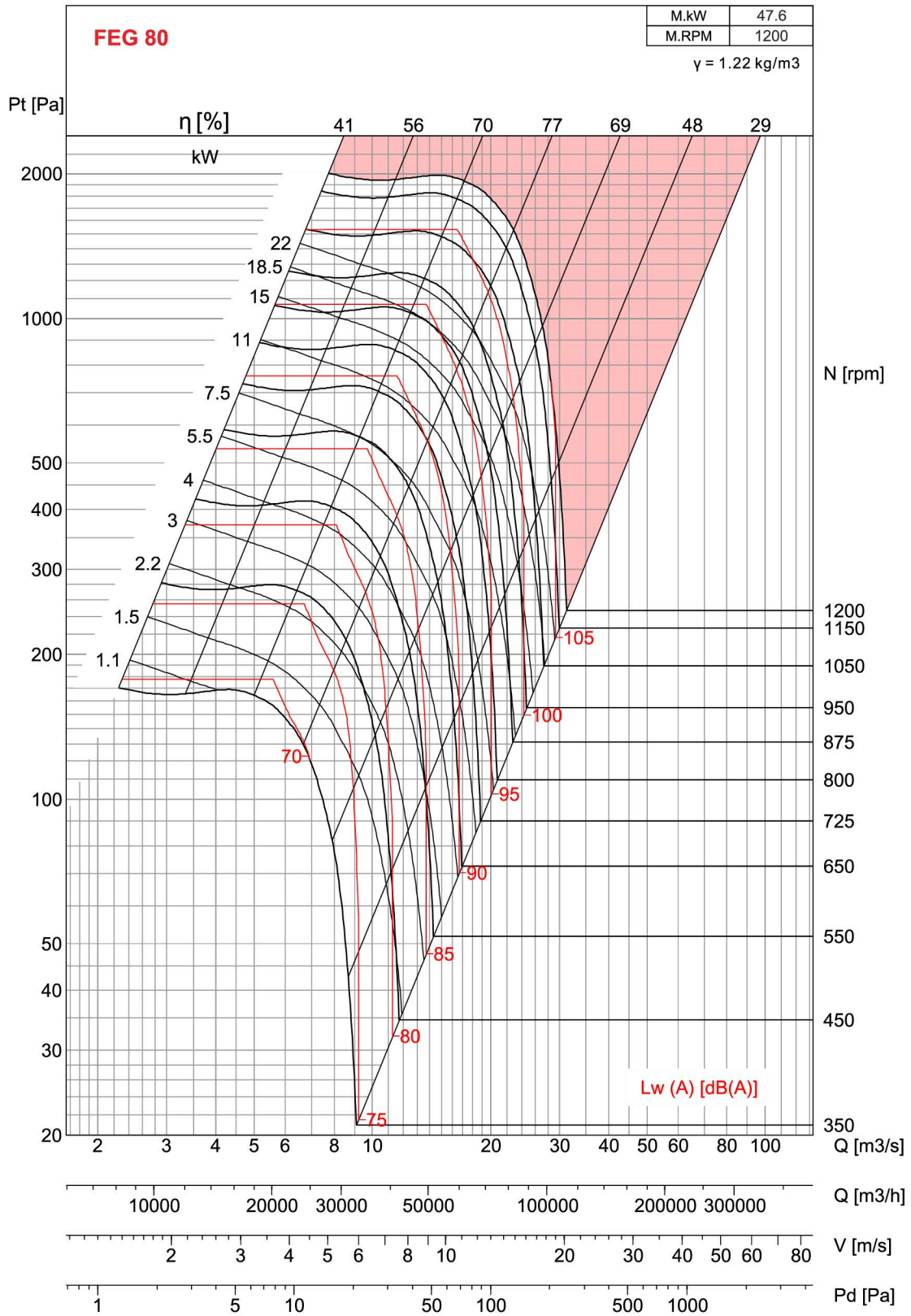

- Performance certified is for Installation type D - Ducted inlet, Ducted outlet. Performance ratings do not include the effects of appurtenances (belt cover). Power rating kW does not include transmission losses.
- The A-weighted sound ratings shown have been calculated per AMCA International Standard 301. Values shown are for inlet Lw A sound power levels for installation type D - Ducted inlet, Ducted outlet. Ratings include the effects of duct end correction.

# MXC 1600

## Selection

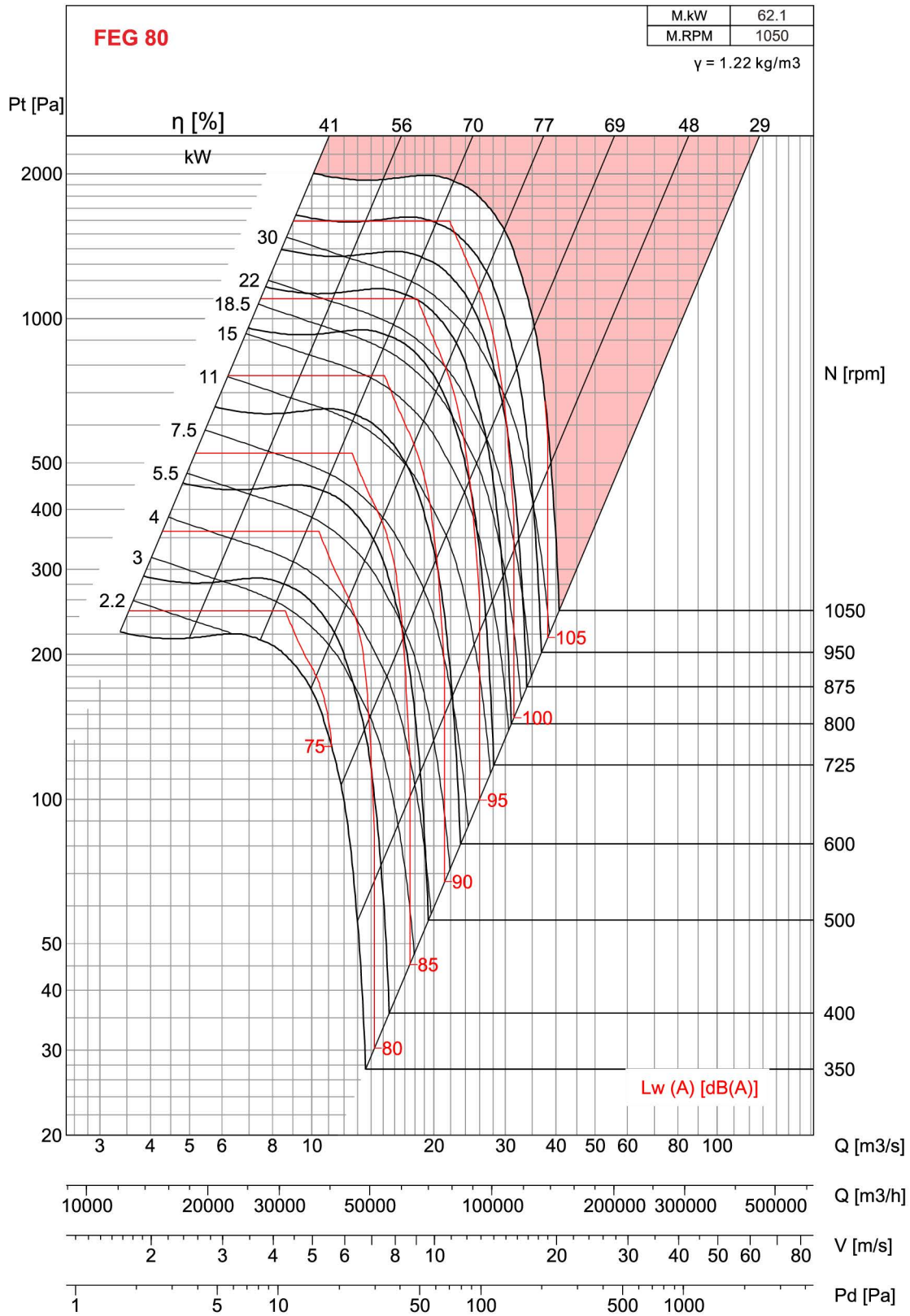

- Performance certified is for Installation type D - Ducted inlet, Ducted outlet. Performance ratings do not include the effects of appurtenances (belt cover). Power rating kW does not include transmission losses.
- The A-weighted sound ratings shown have been calculated per AMCA International Standard 301. Values shown are for inlet Lw A sound power levels for installation type D - Ducted inlet, Ducted outlet. Ratings include the effects of duct end correction.

# MXC 1800

## Selection

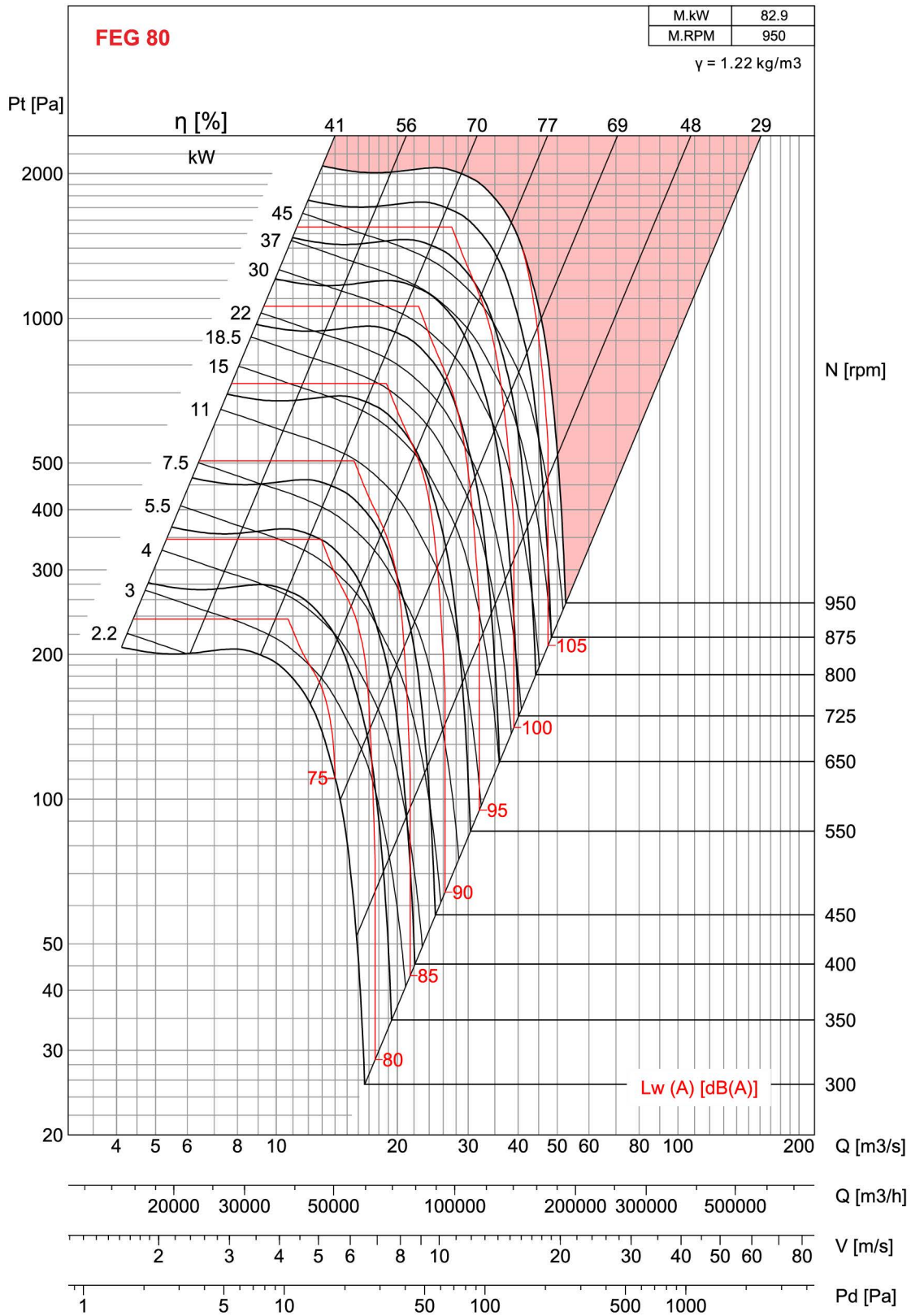

- Performance certified is for Installation type D - Ducted inlet, Ducted outlet. Performance ratings do not include the effects of appurtenances (belt cover). Power rating kW does not include transmission losses.
- The A-weighted sound ratings shown have been calculated per AMCA International Standard 301. Values shown are for inlet Lwi A sound power levels for installation type D - Ducted inlet, Ducted outlet. Ratings include the effects of duct end correction.

# MXC 2000

## Selection

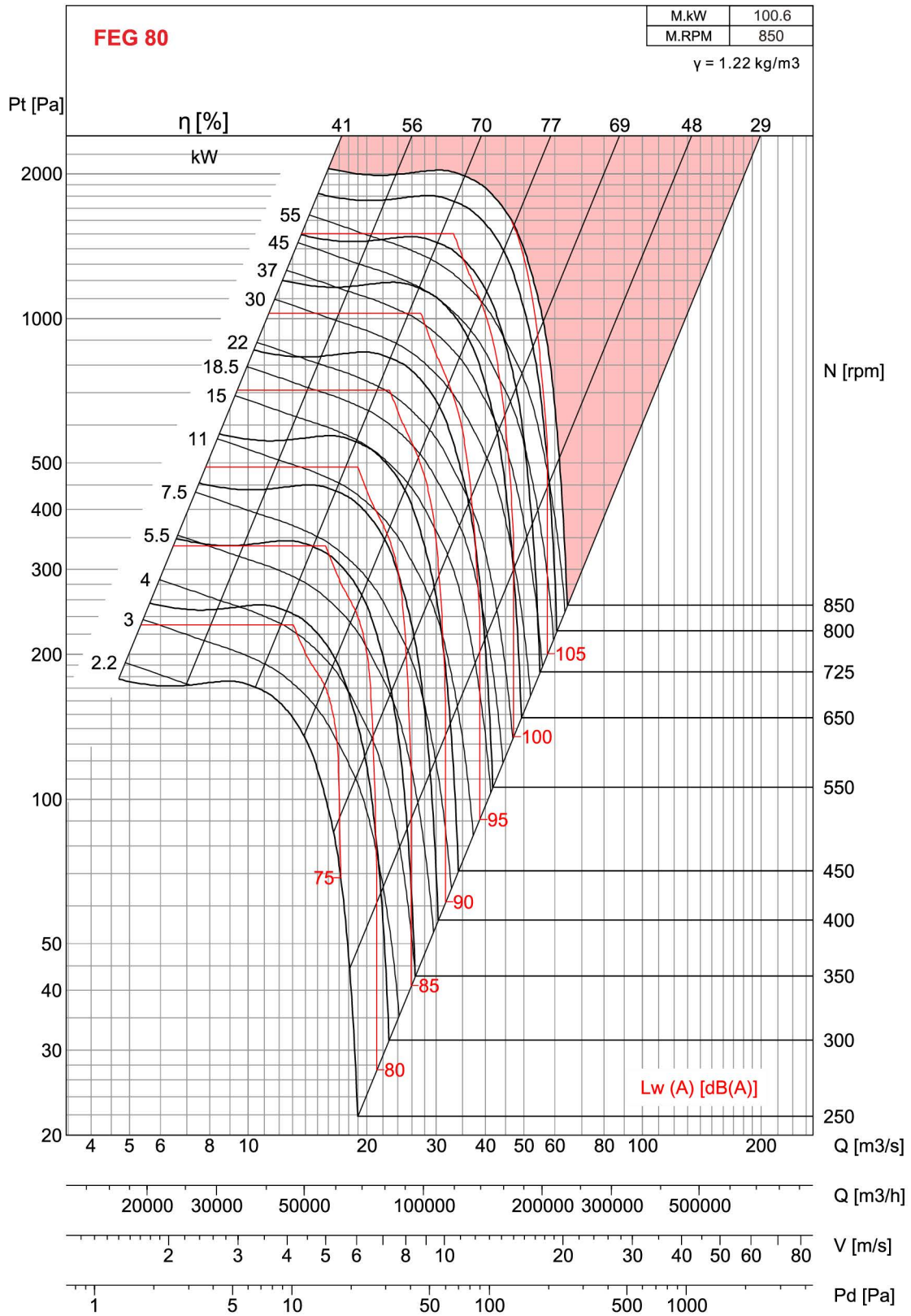

- Performance certified is for Installation type D - Ducted inlet, Ducted outlet. Performance ratings do not include the effects of appurtenances (belt cover). Power rating kW does not include transmission losses.
- The A-weighted sound ratings shown have been calculated per AMCA International Standard 301. Values shown are for inlet Lwi A sound power levels for installation type D - Ducted inlet, Ducted outlet. Ratings include the effects of duct end correction.

# MXC 355-Bi

## Selection

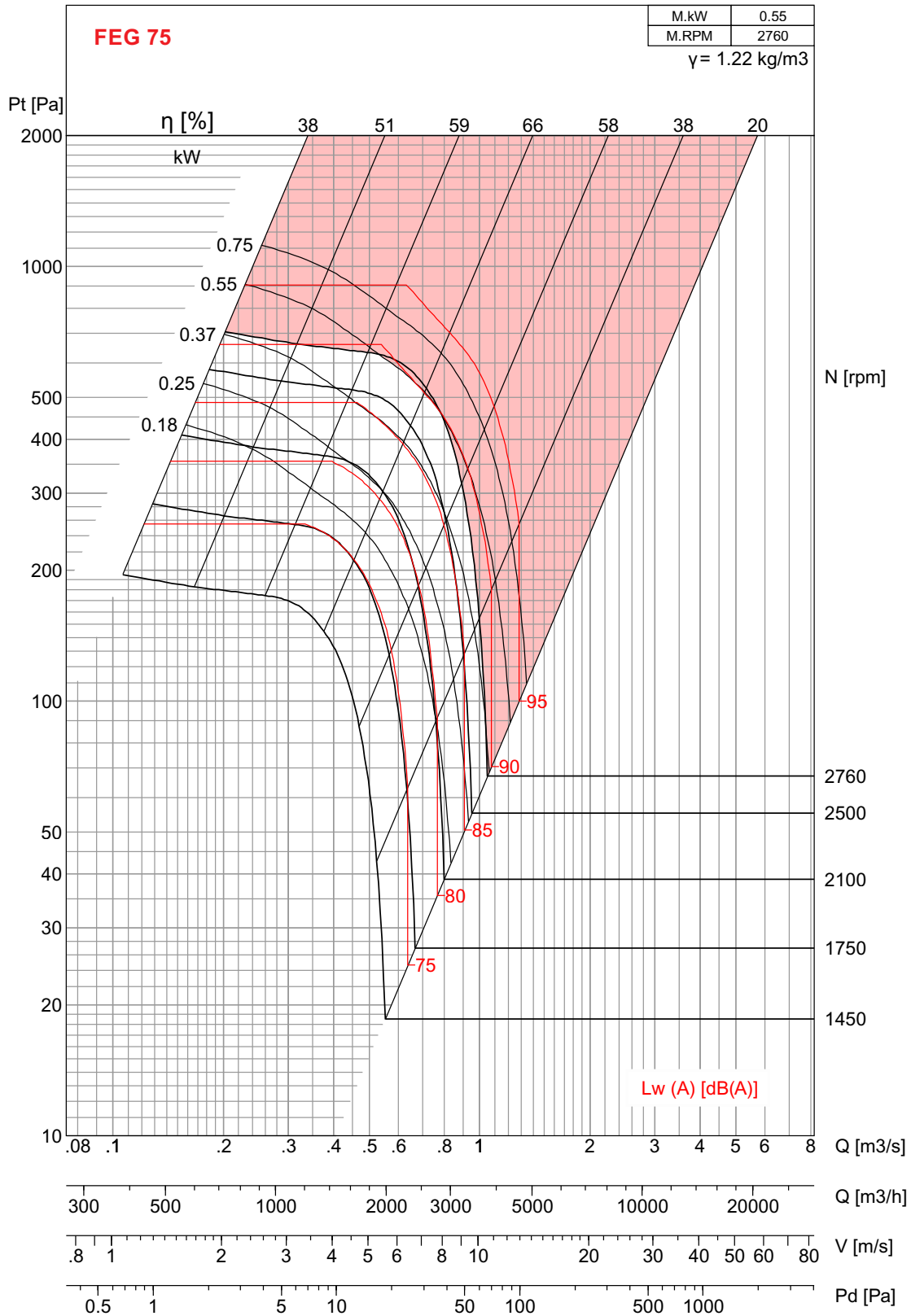

- Performance shown is for Installation type D – Ducted inlet, Ducted outlet. Performance ratings do not include the effects of appurtenances (accessories).
- The A-weighted sound ratings shown have been calculated per AMCA International Standard 301. Values shown are for inlet Lwi A sound power levels for installation type D – Ducted inlet, Ducted outlet. Ratings include the effects of duct end correction.

# MXC 400-Bi

## Selection

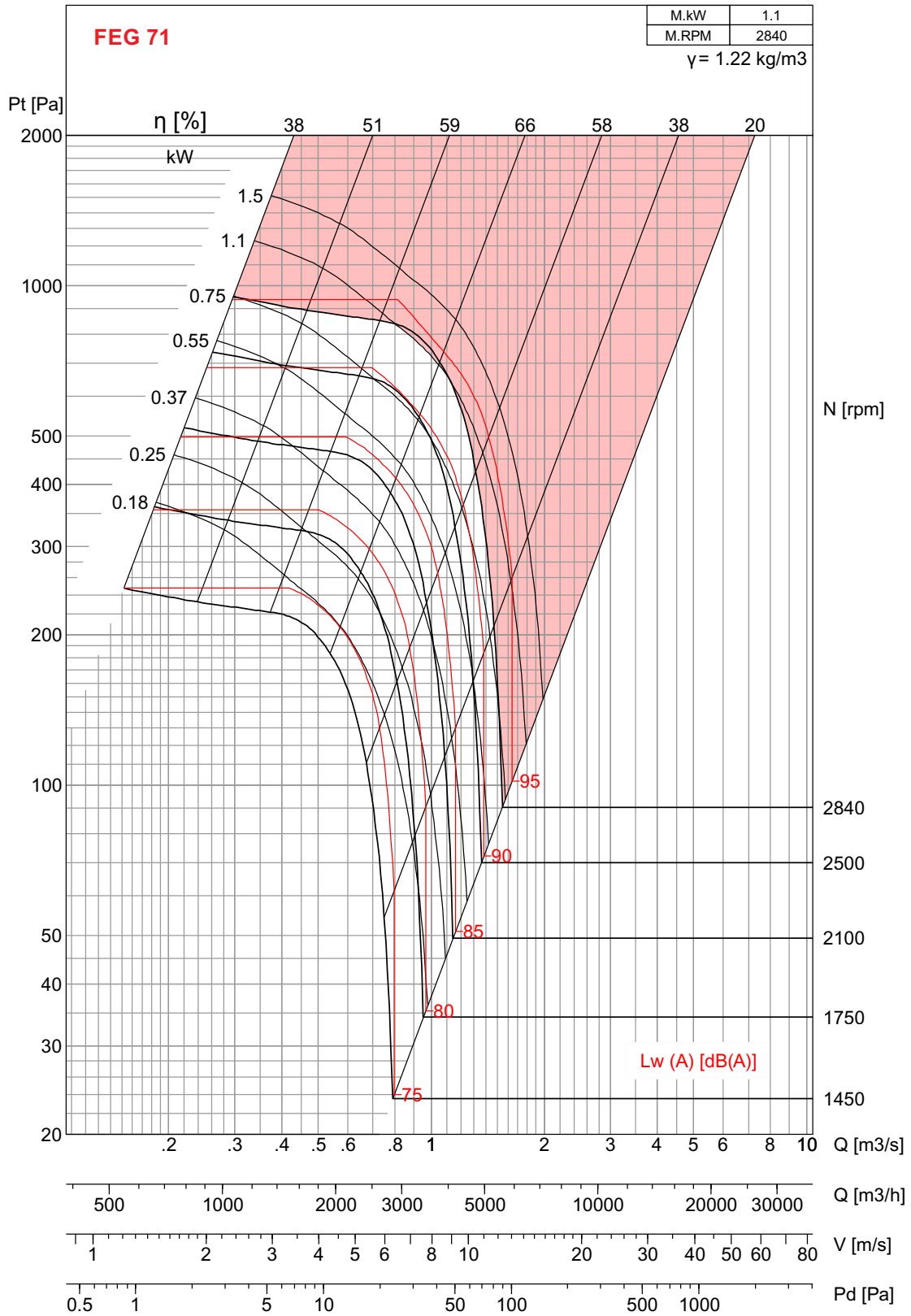

- Performance shown is for Installation type D – Ducted inlet, Ducted outlet. Performance ratings do not include the effects of appurtenances (accessories).
- The A-weighted sound ratings shown have been calculated per AMCA International Standard 301. Values shown are for inlet Lwi A sound power levels for installation type D – Ducted inlet, Ducted outlet. Ratings include the effects of duct end correction.

# MXC 450-Bi

## Selection

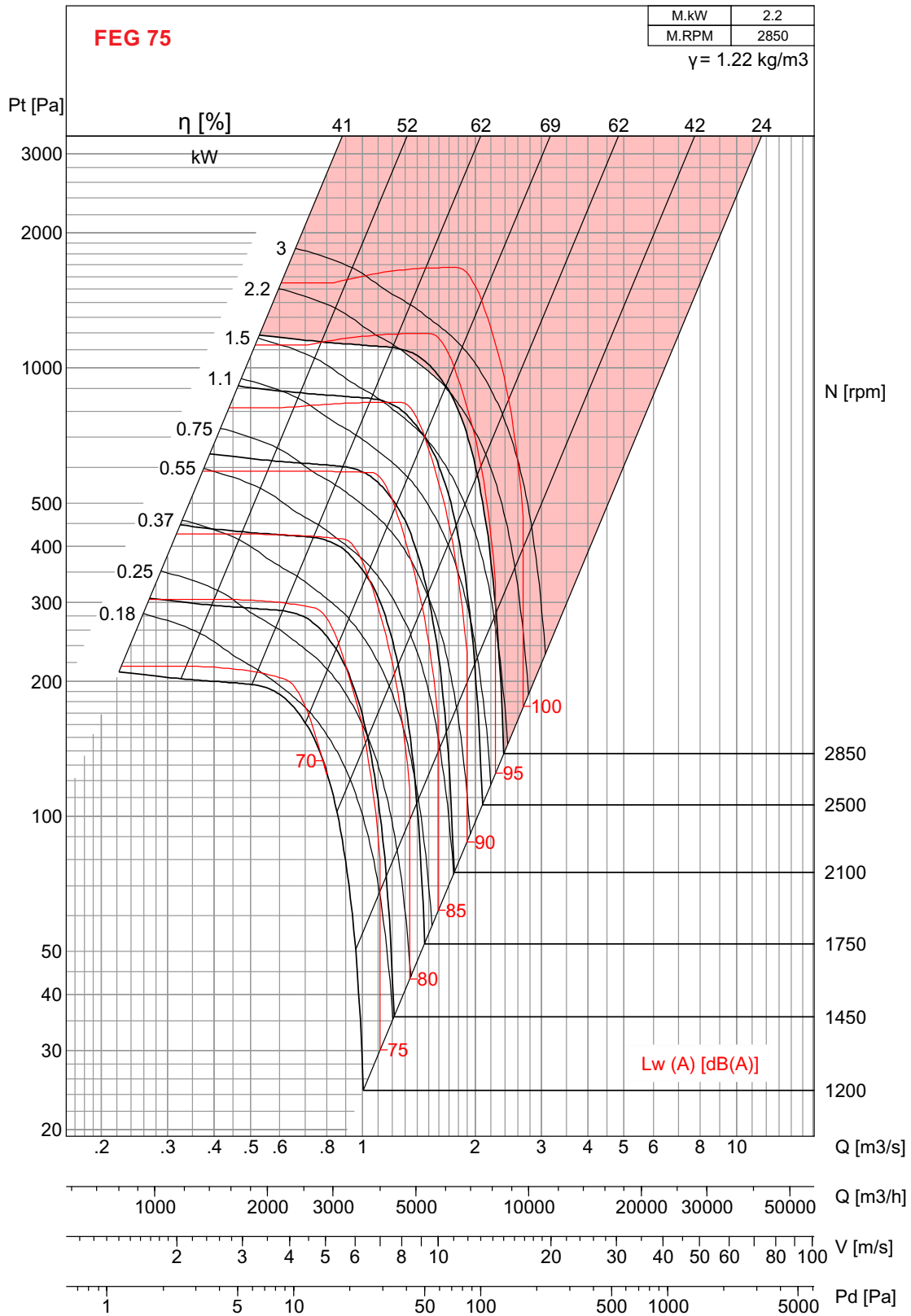

- Performance shown is for Installation type D – Ducted inlet, Ducted outlet. Performance ratings do not include the effects of appurtenances (accessories).
- The A-weighted sound ratings shown have been calculated per AMCA International Standard 301. Values shown are for inlet Lwi A sound power levels for installation type D – Ducted inlet, Ducted outlet. Ratings include the effects of duct end correction.

# MXC 500-Bi

## Selection

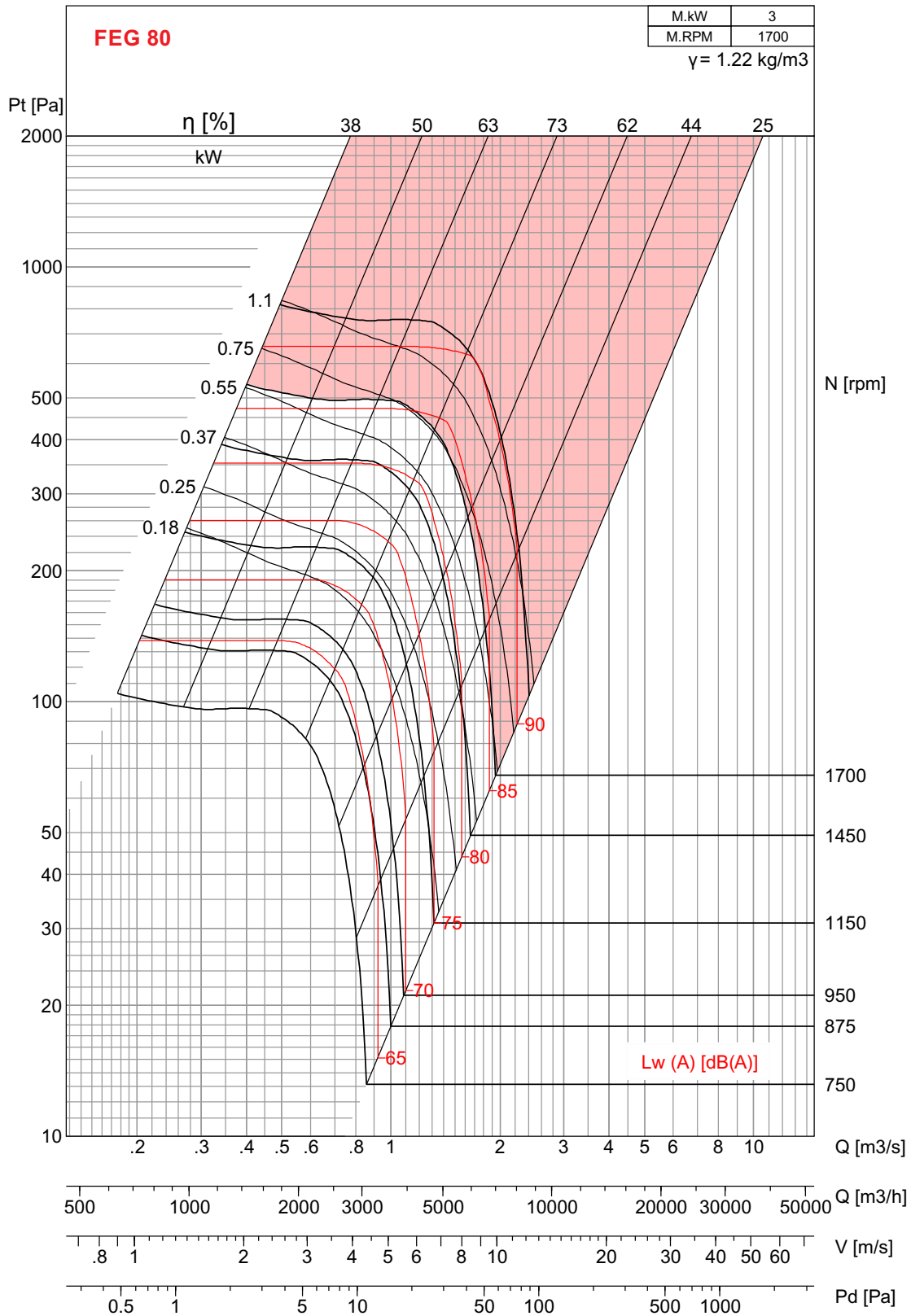

- Performance shown is for Installation type D – Ducted inlet, Ducted outlet. Performance ratings do not include the effects of appurtenances (accessories).
- The A-weighted sound ratings shown have been calculated per AMCA International Standard 301. Values shown are for inlet Lwi A sound power levels for installation type D – Ducted inlet, Ducted outlet. Ratings include the effects of duct end correction.

# MXC 560-Bi

## Selection

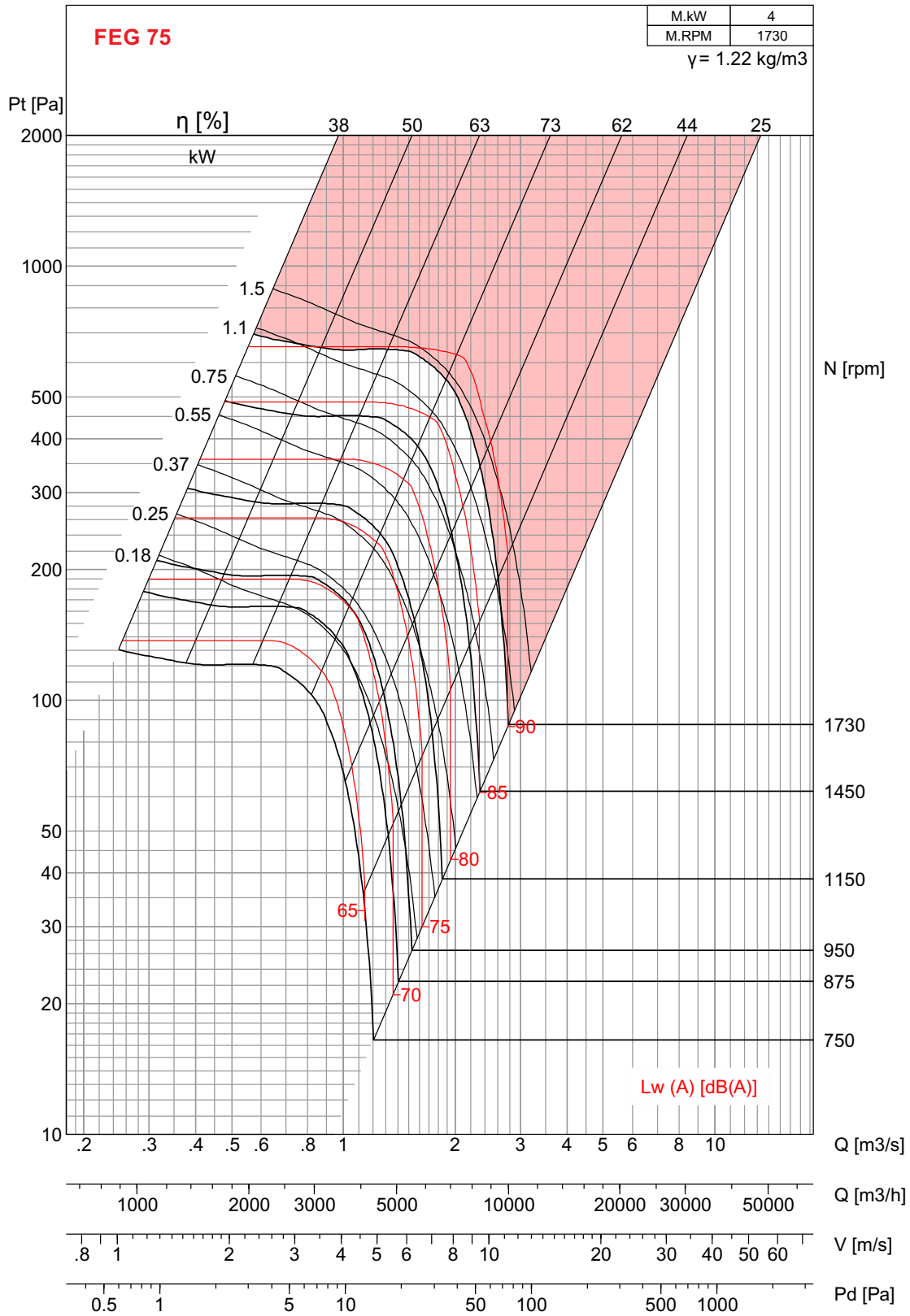

- Performance shown is for Installation type D – Ducted inlet, Ducted outlet. Performance ratings do not include the effects of appurtenances (accessories).
- The A-weighted sound ratings shown have been calculated per AMCA International Standard 301. Values shown are for inlet Lwi A sound power levels for installation type D – Ducted inlet, Ducted outlet. Ratings include the effects of duct end correction.

# MXC 630-Bi

## Selection

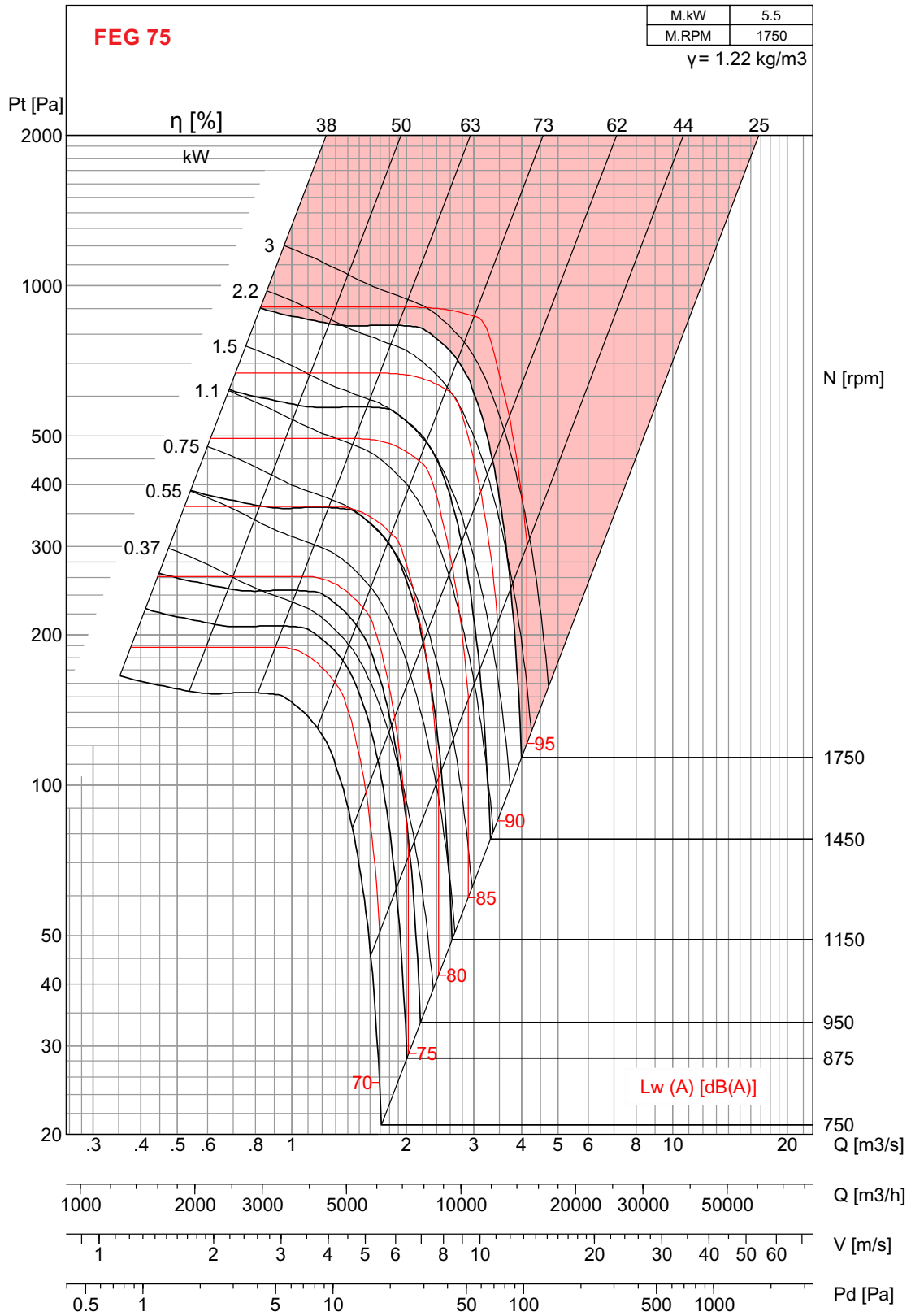

- Performance shown is for Installation type D – Ducted inlet, Ducted outlet. Performance ratings do not include the effects of appurtenances (accessories).
- The A-weighted sound ratings shown have been calculated per AMCA International Standard 301. Values shown are for inlet Lwi A sound power levels for installation type D – Ducted inlet, Ducted outlet. Ratings include the effects of duct end correction.

# MXC 710-Bi

## Selection

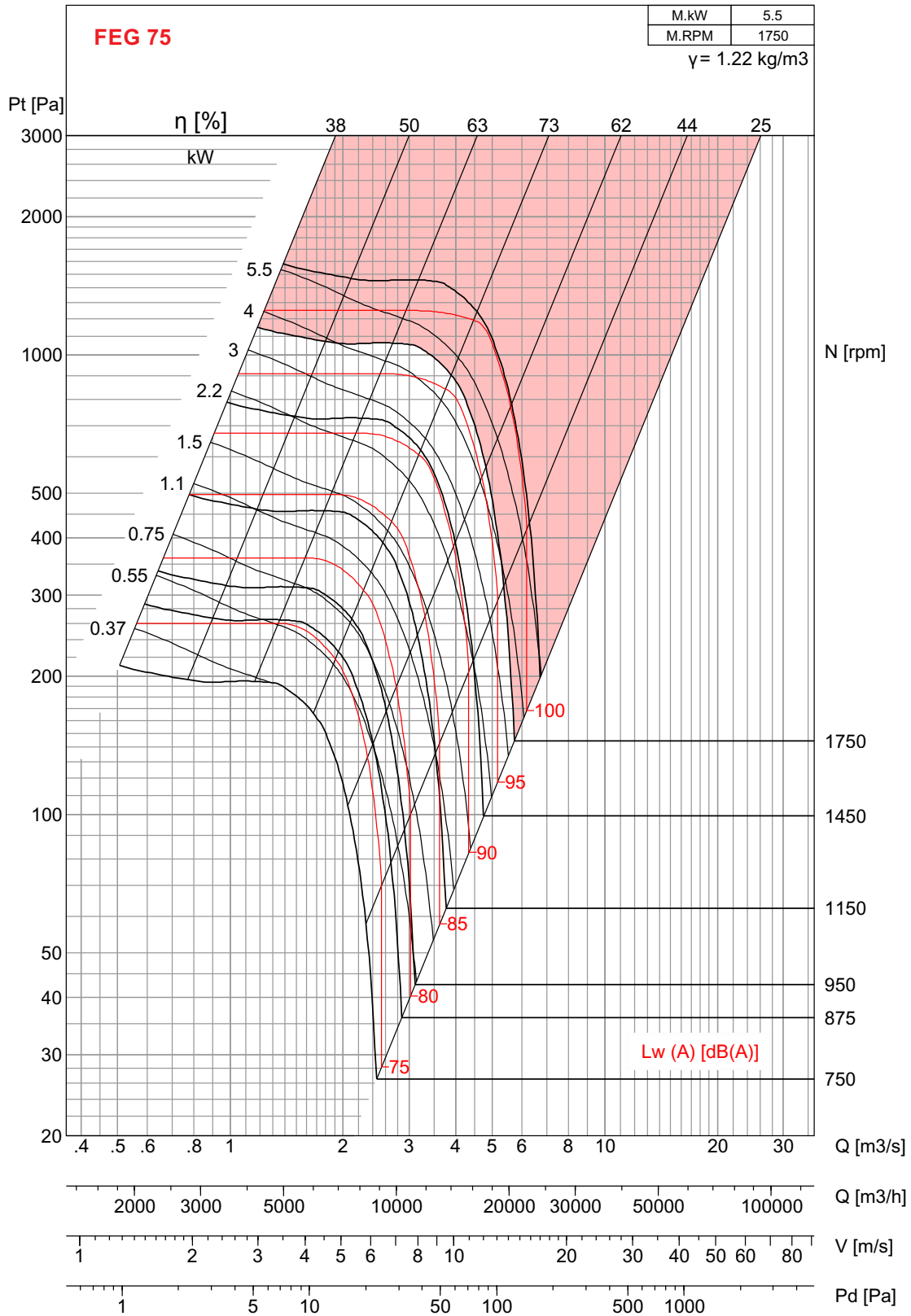

- Performance shown is for Installation type D – Ducted inlet, Ducted outlet. Performance ratings do not include the effects of appurtenances (accessories).
- The A-weighted sound ratings shown have been calculated per AMCA International Standard 301. Values shown are for inlet Lwi A sound power levels for installation type D – Ducted inlet, Ducted outlet. Ratings include the effects of duct end correction.

# MXC 800-Bi

## Selection

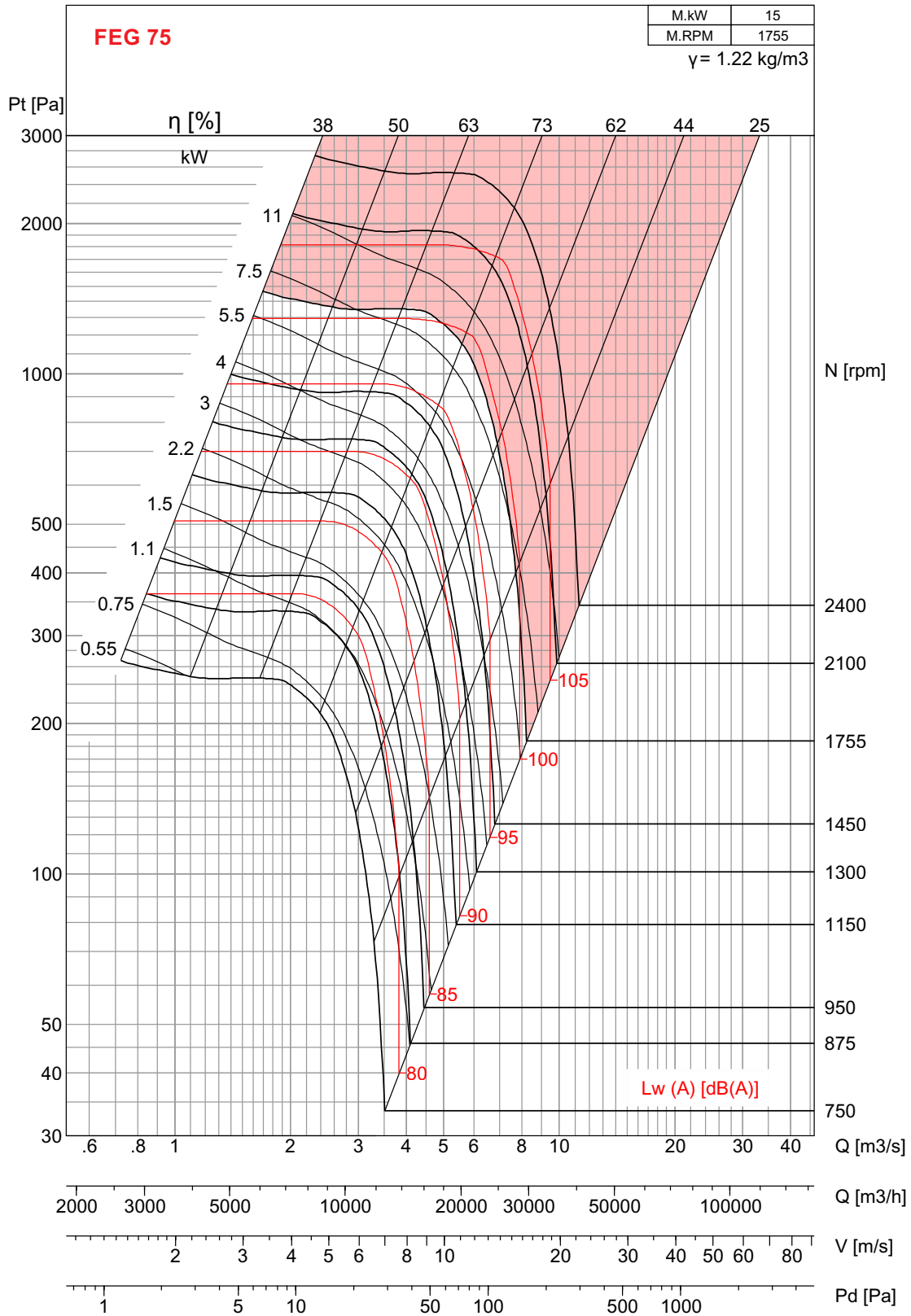

- Performance shown is for Installation type D – Ducted inlet, Ducted outlet. Performance ratings do not include the effects of appurtenances (accessories).
- The A-weighted sound ratings shown have been calculated per AMCA International Standard 301. Values shown are for inlet Lwi A sound power levels for installation type D – Ducted inlet, Ducted outlet. Ratings include the effects of duct end correction.

# MXC 900-Bi

## Selection

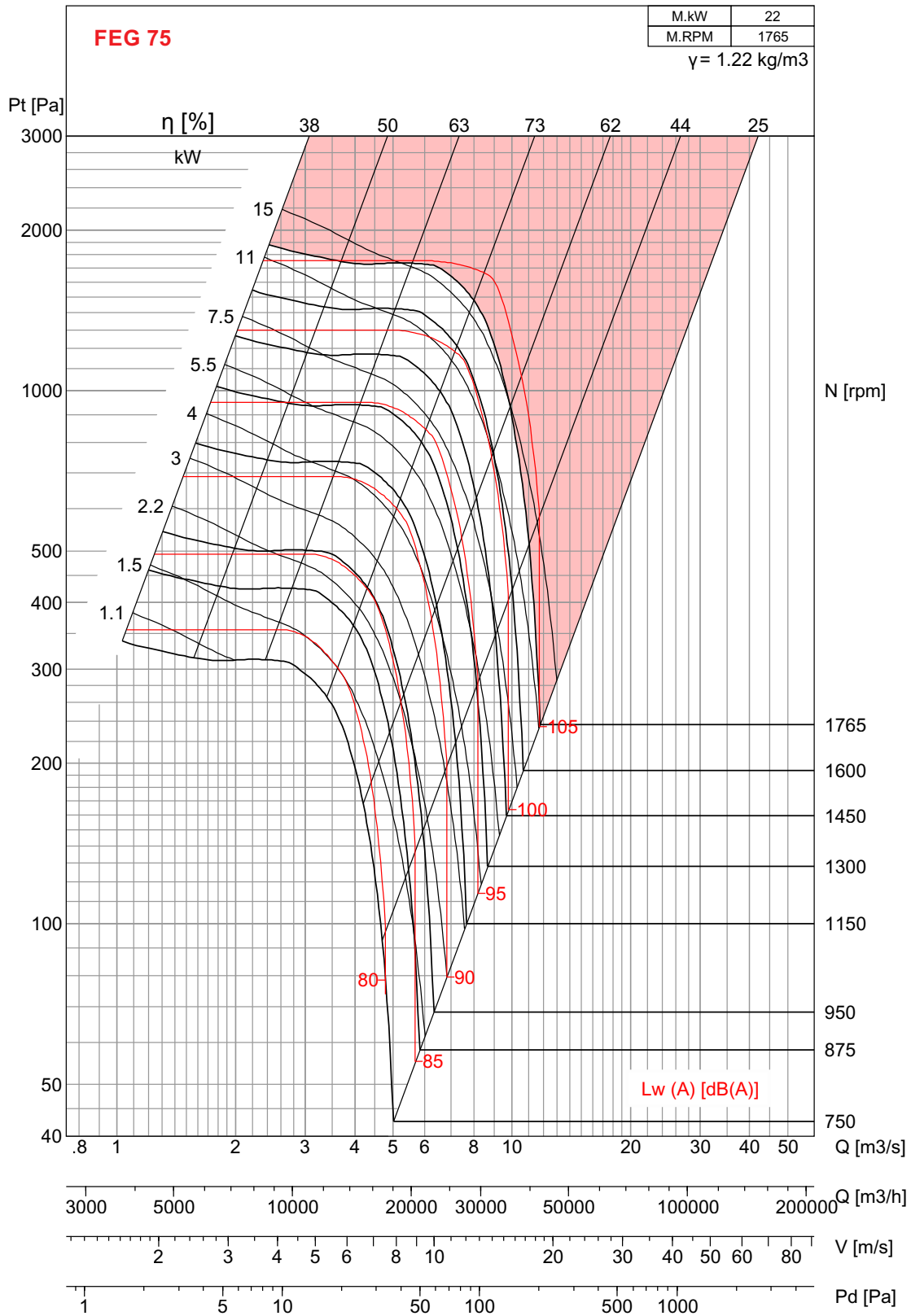

- Performance shown is for Installation type D – Ducted inlet, Ducted outlet. Performance ratings do not include the effects of appurtenances (accessories).
- The A-weighted sound ratings shown have been calculated per AMCA International Standard 301. Values shown are for inlet Lwi A sound power levels for installation type D – Ducted inlet, Ducted outlet. Ratings include the effects of duct end correction.

# MXC 1000-Bi

## Selection

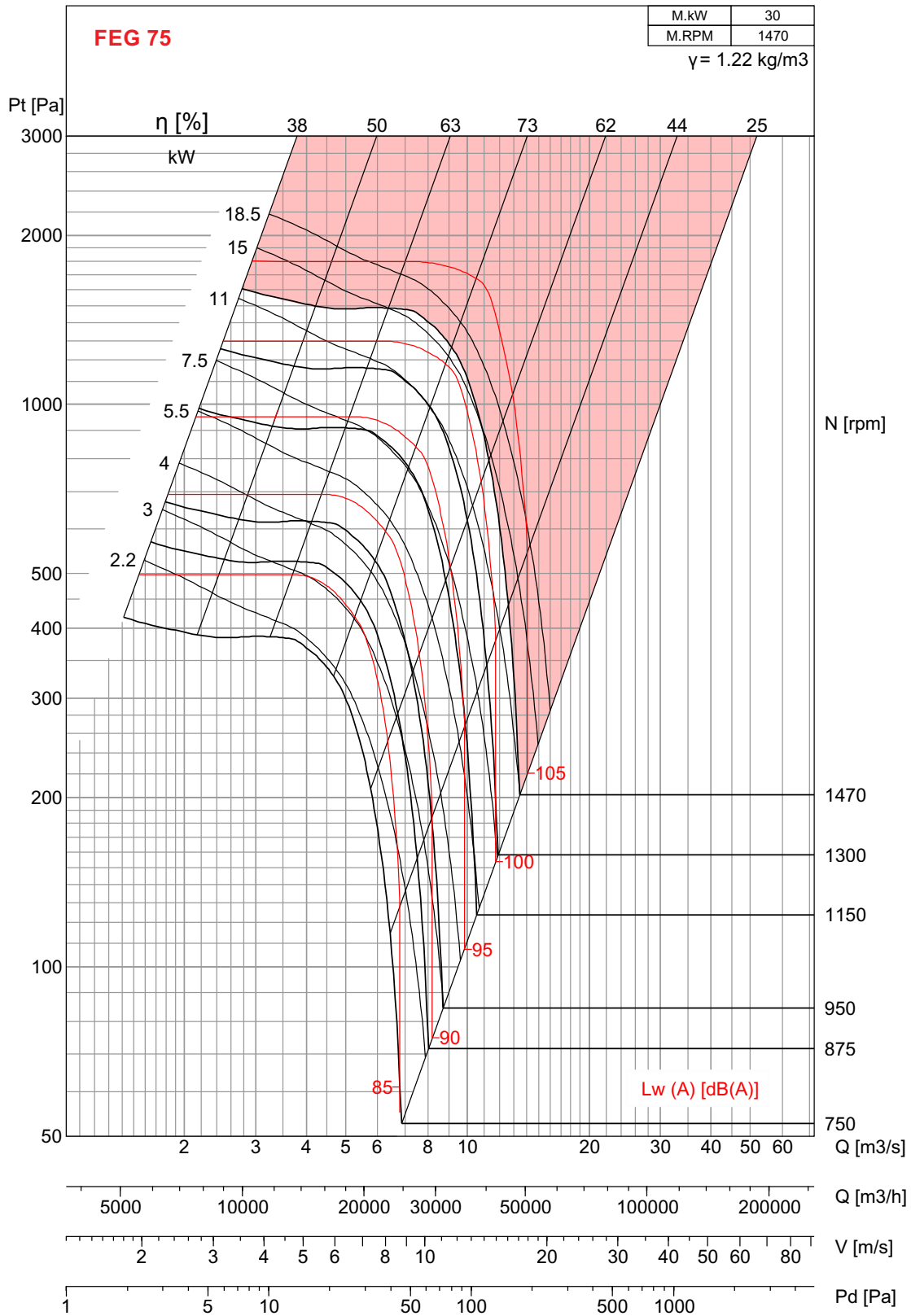

- Performance shown is for Installation type D – Ducted inlet, Ducted outlet. Performance ratings do not include the effects of appurtenances (accessories).
- The A-weighted sound ratings shown have been calculated per AMCA International Standard 301. Values shown are for inlet Lwi A sound power levels for installation type D – Ducted inlet, Ducted outlet. Ratings include the effects of duct end correction.

# Fan Energy Index

## Example of FEI Selection

Air Volume  $Q = 10.31 \text{ m}^3/\text{s}$   
 Fan Speed  $N = 1450 \text{ rpm}$   
 FEI = 1.33

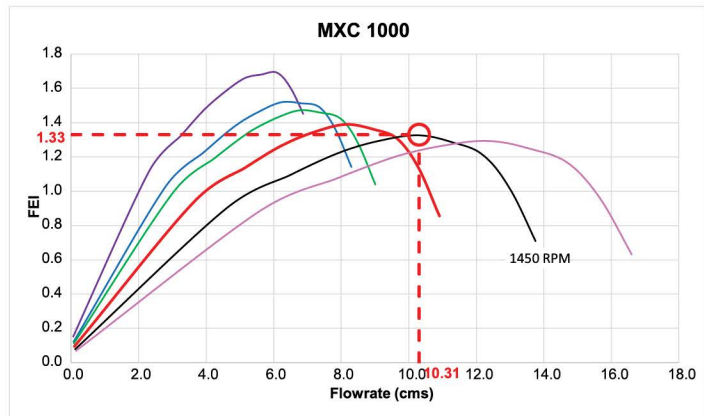

## Direct drive models

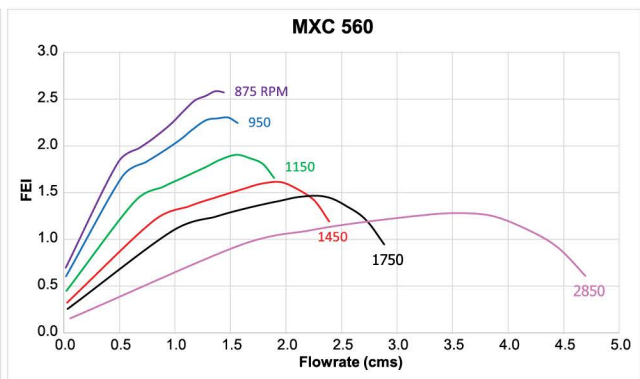
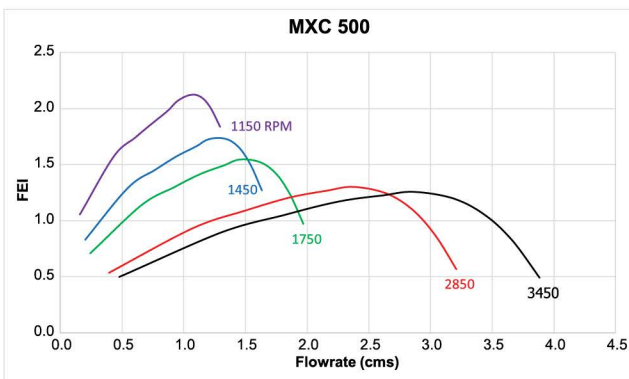
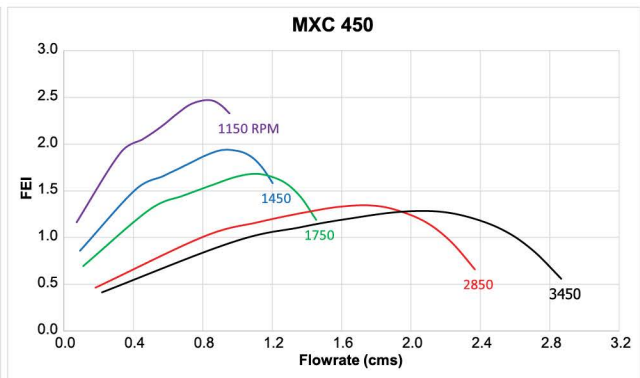
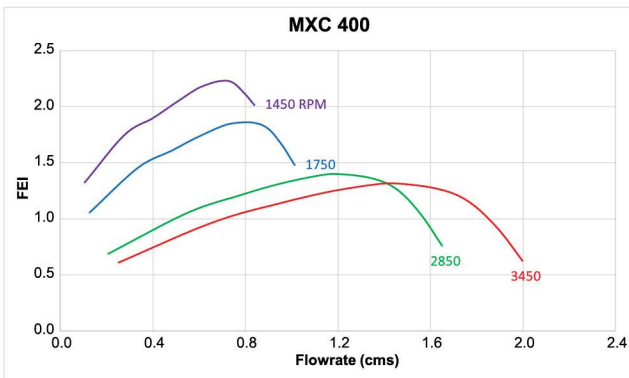
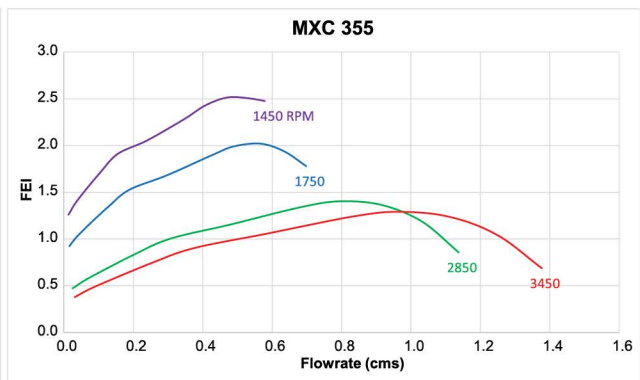
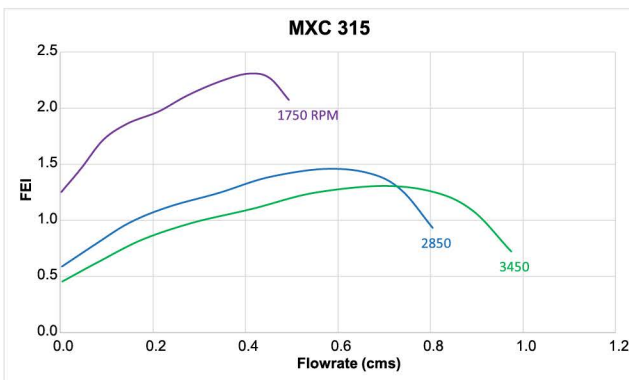

Performance certified is for installation type D - Ducted inlet, Ducted outlet. Power rating (kW) does not include transmission losses. Performance ratings do not include the effects of appurtenances (accessories). FEI<sub>i</sub> values are calculated in accordance with ANSI/AMCA Standard 208 and are based on default motor efficiencies (Direct Driven type). FEI<sub>i</sub> values for fans with specific motors will vary slightly from those shown. Fan speed shown in RPM.

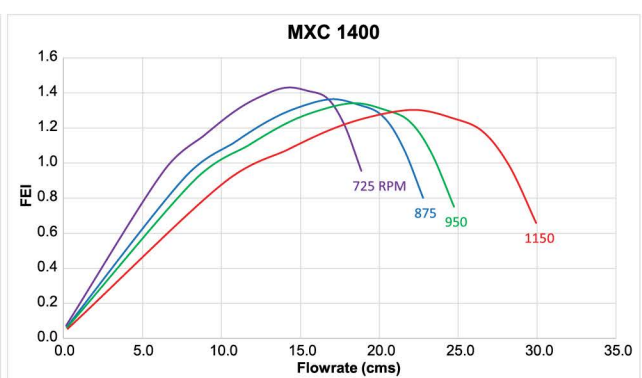
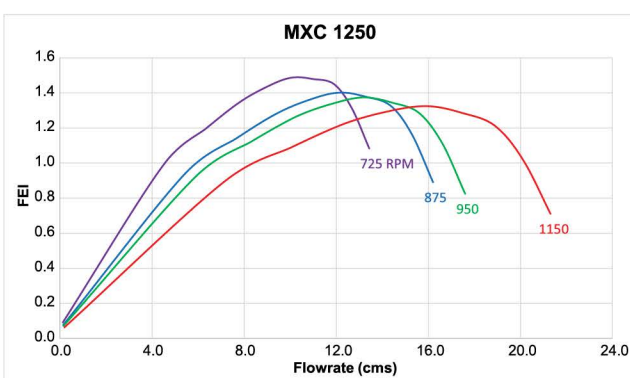
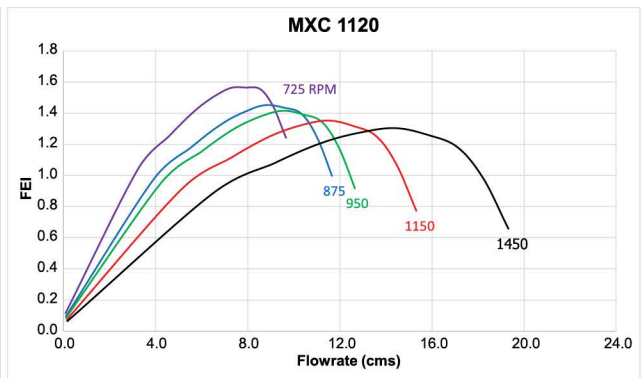
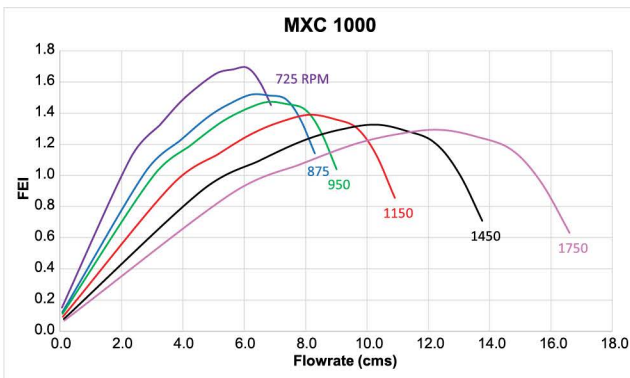
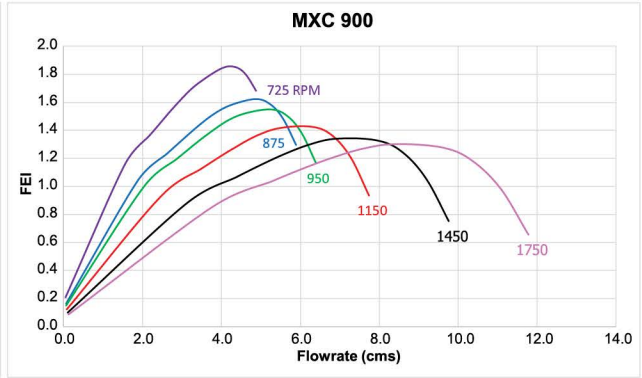
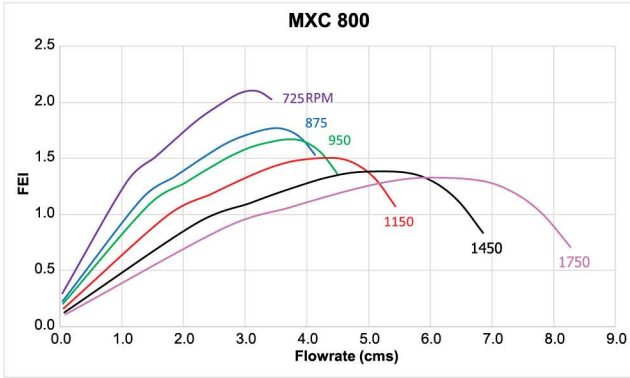
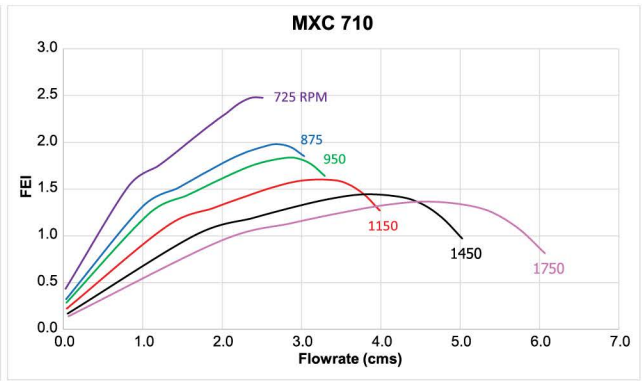
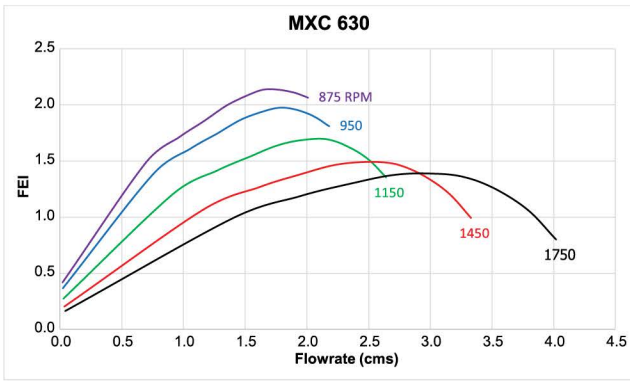

Performance certified is for installation type D - Ducted inlet, Ducted outlet. Power rating (kW) does not include transmission losses. Performance ratings do not include the effects of appurtenances (accessories). FEI<sub>1</sub> values are calculated in accordance with ANSI/AMCA Standard 208 and are based on default motor efficiencies (Direct Driven type). FEI<sub>1</sub> values for fans with specific motors will vary slightly from those shown. Fan speed shown in RPM.

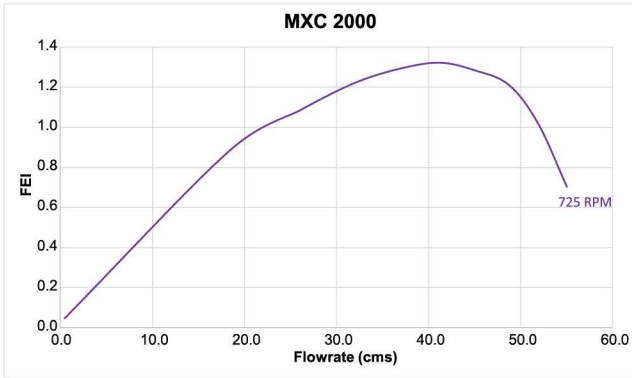
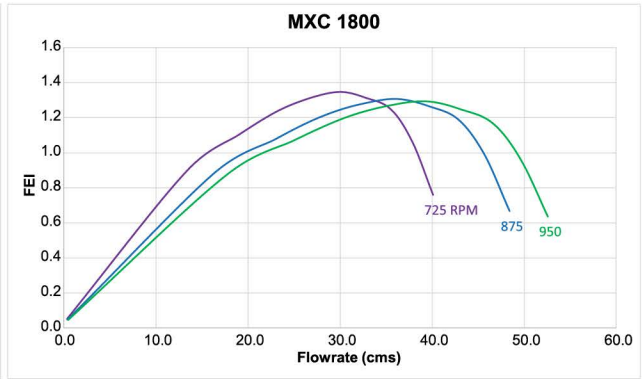
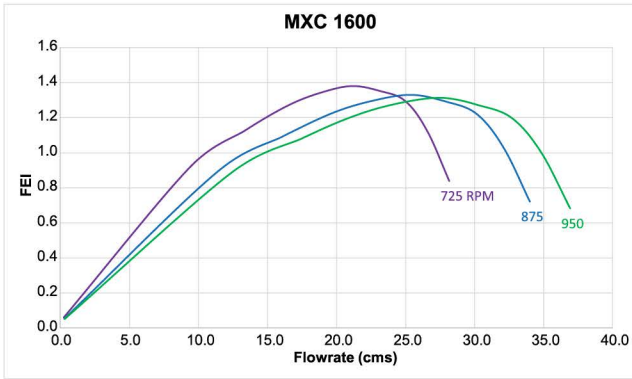

Performance certified is for installation type D - Ducted inlet, Ducted outlet. Power rating (kW) does not include transmission losses. Performance ratings do not include the effects of appurtenances (accessories).  $FEI_1$  values are calculated in accordance with ANSI/AMCA Standard 208 and are based on default motor efficiencies (Direct Driven type).  $FEI_1$  values for fans with specific motors will vary slightly from those shown. Fan speed shown in RPM.

## Belt drive models

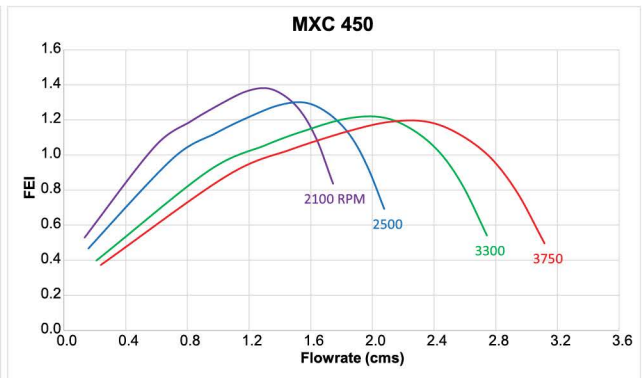
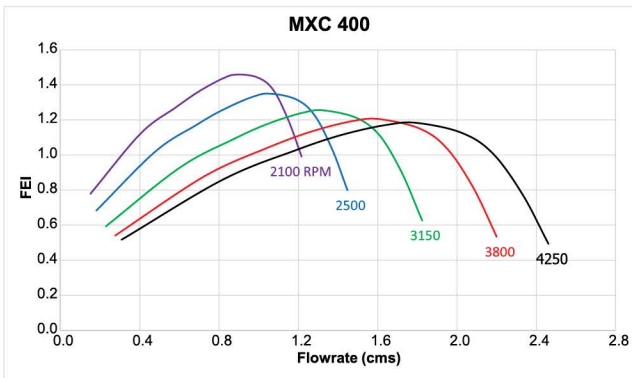
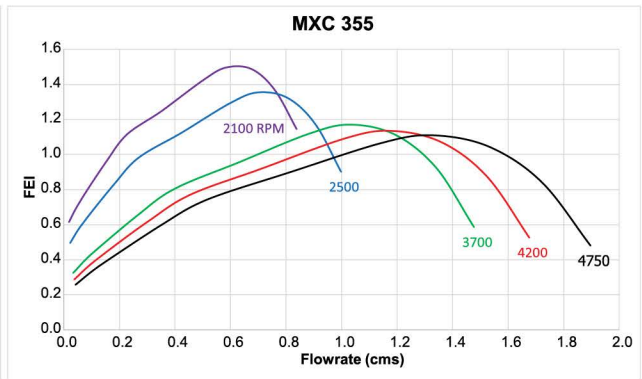
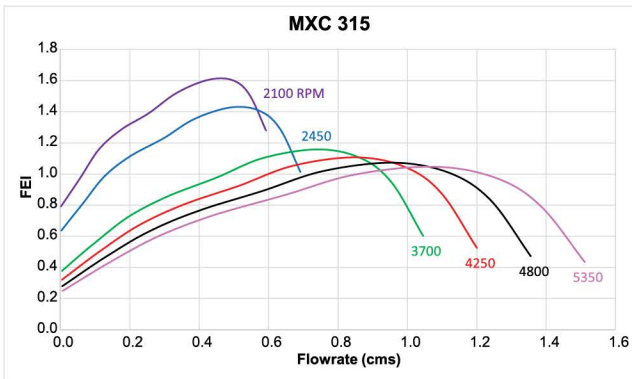

Performance certified is for installation type D - Ducted inlet, Ducted outlet. Power rating (kW) does not include transmission losses. Performance ratings do not include the effects of appurtenances (belt cover).  $FEI_1$  values are calculated in accordance with ANSI/AMCA Standard 208 and are based on default motor efficiencies (Belt Driven type).  $FEI_1$  values for fans with specific motors will vary slightly from those shown. Fan speed shown in RPM.

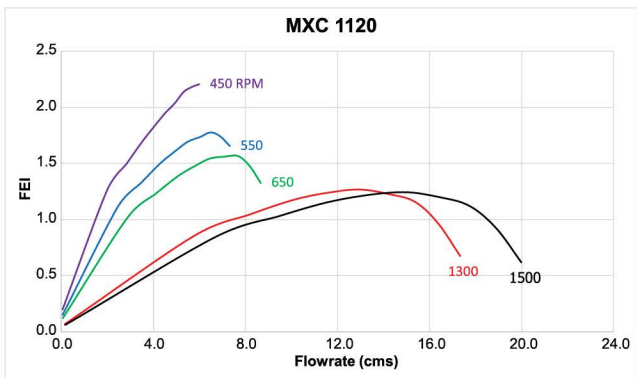
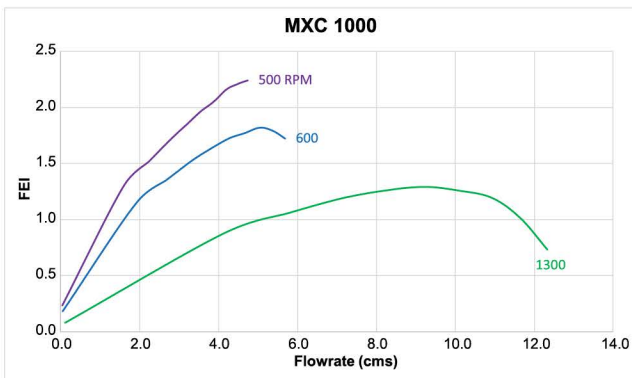
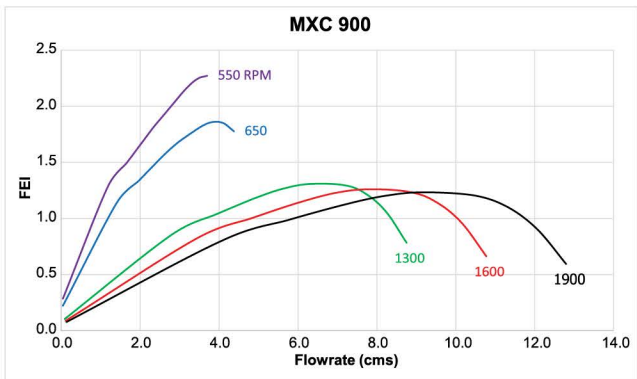
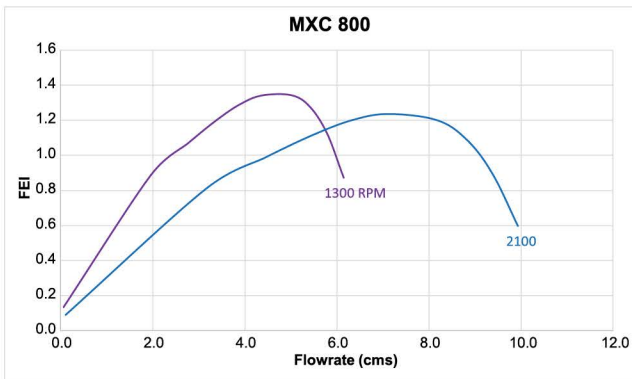
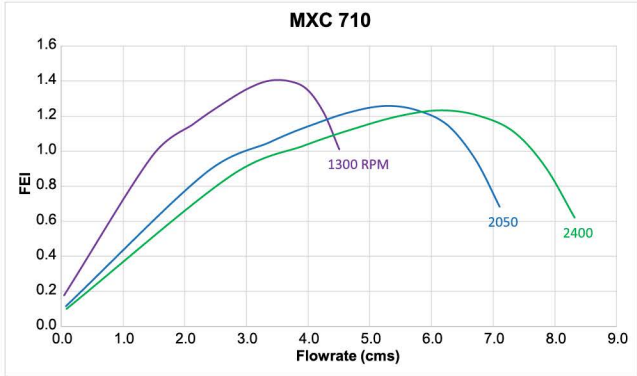
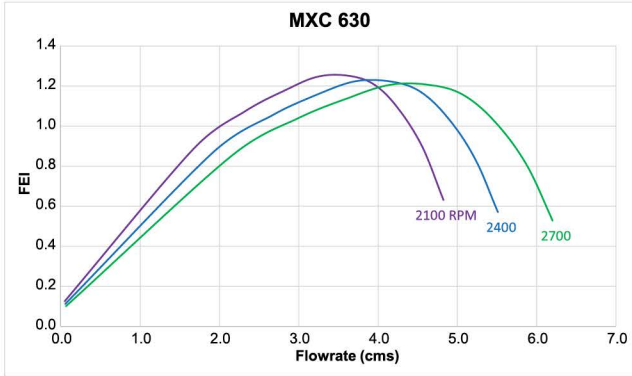
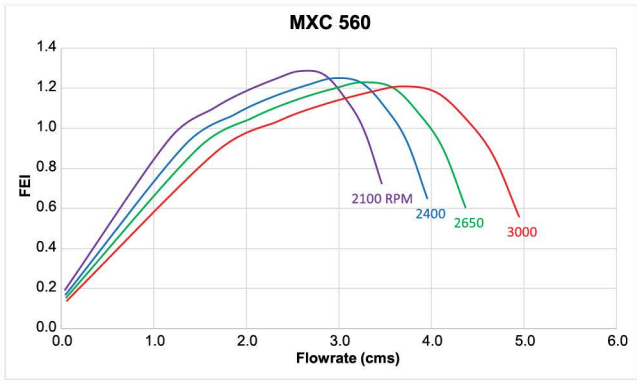
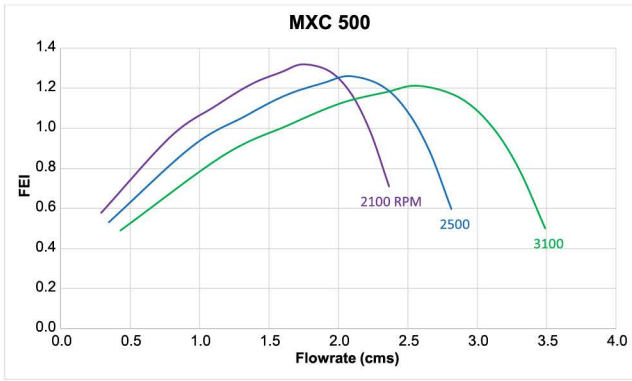

Performance certified is for installation type D - Ducted inlet, Ducted outlet. Power rating (kW) does not include transmission losses. Performance ratings do not include the effects of appurtenances (belt cover). FEI<sub>i</sub> values are calculated in accordance with ANSI/AMCA Standard 208 and are based on default motor efficiencies (Belt Driven type). FEI<sub>i</sub> values for fans with specific motors will vary slightly from those shown. Fan speed shown in RPM.

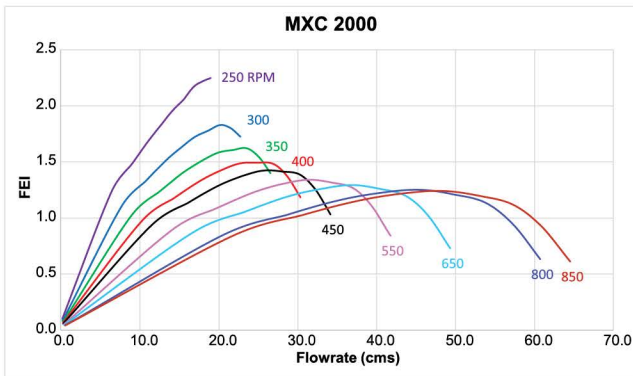
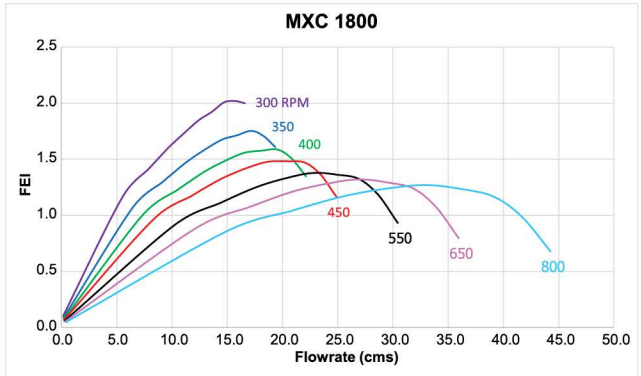
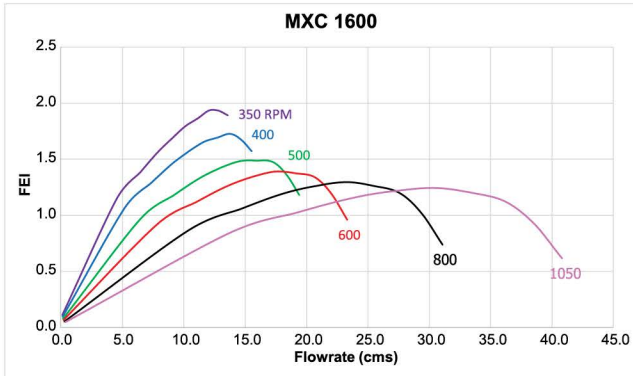
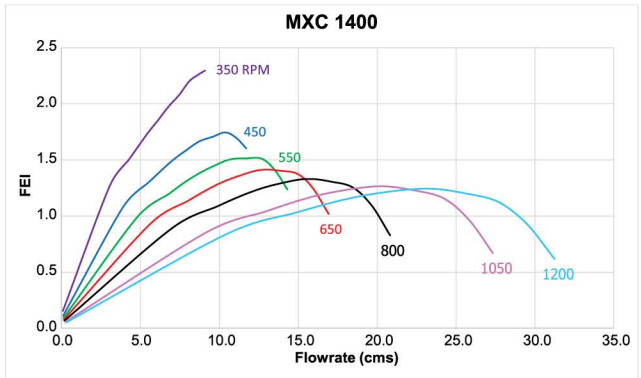
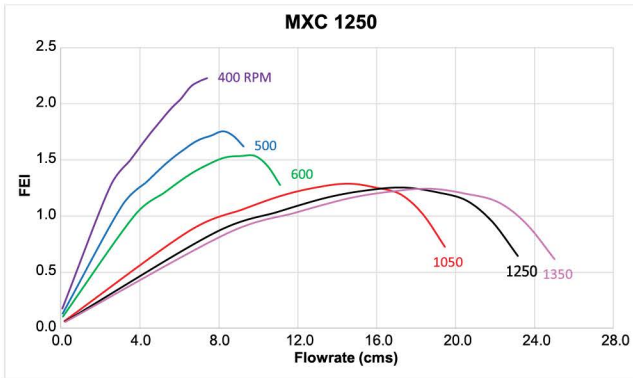

Performance certified is for installation type D - Ducted inlet, Ducted outlet. Power rating (kW) does not include transmission losses. Performance ratings do not include the effects of appurtenances (belt cover). FEI<sub>r</sub> values are calculated in accordance with ANSI/AMCA Standard 208 and are based on default motor efficiencies (Belt Driven type). FEI<sub>r</sub> values for fans with specific motors will vary slightly from those shown. Fan speed shown in RPM.

# MXC Bifurcated direct drive models

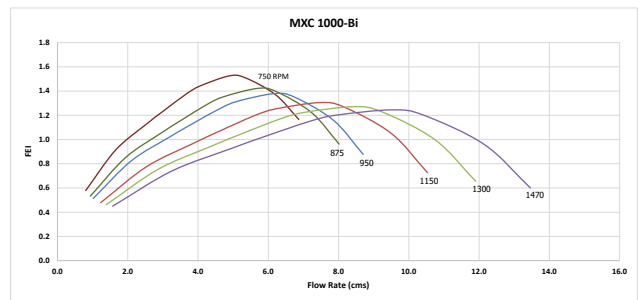
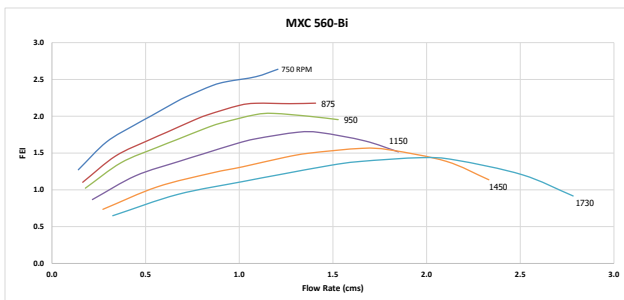
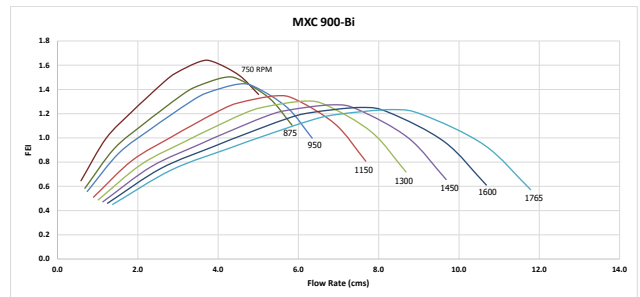
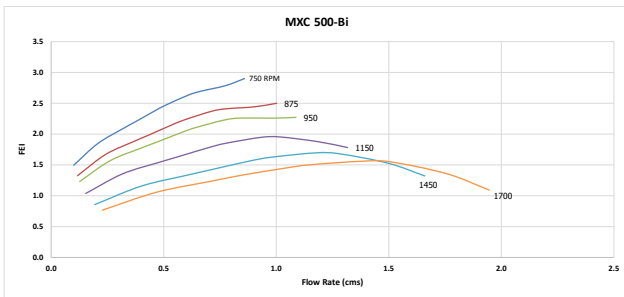
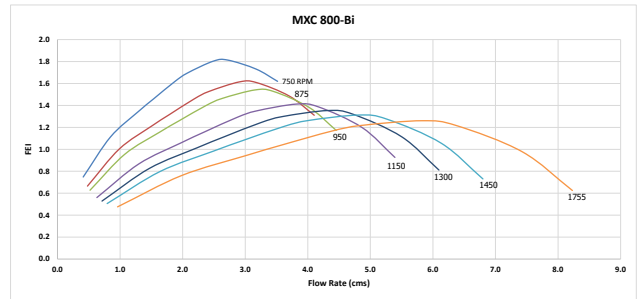
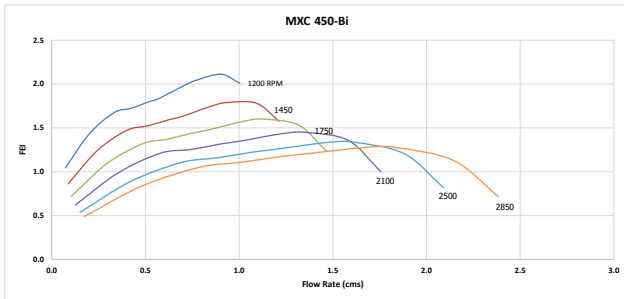
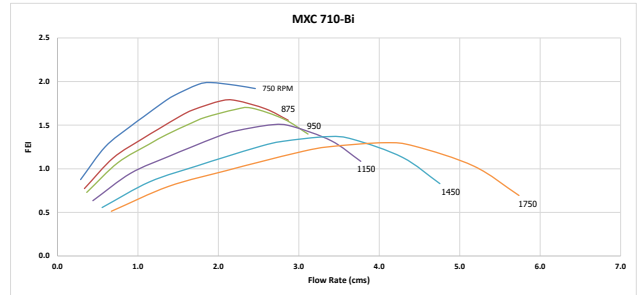
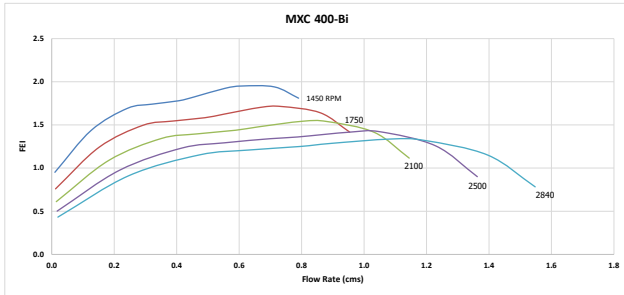
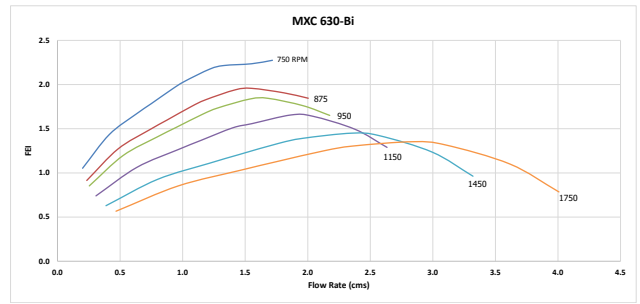
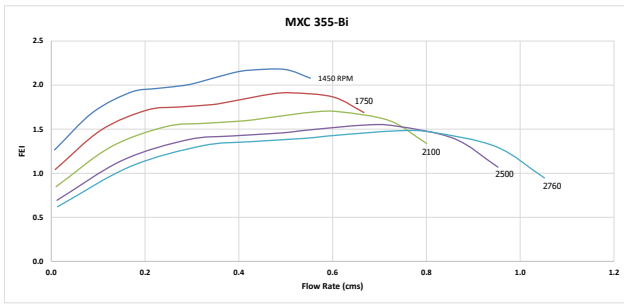

Performance shown is for installation type D - Ducted inlet, Ducted outlet. Performance ratings do not include the effects of appurtenances (accessories). FEI<sub>i</sub> values are calculated in accordance with ANSI/AMCA Standard 208 and are based on default motor efficiencies (Direct Driven type). FEI<sub>i</sub> values for fans with specific motors will vary slightly from those shown. Fan speed shown in RPM.

▶ **THAILAND (Regional Head Quarter)**

**KRUGER VENTILATION INDUSTRIES ASIA CO., LTD.**  
30/159 Moo 1, Sinsakorn Industrial Estate, Chetsadawithi Road,  
Khok Kham Mueng, Samuthsakorn 74000, Thailand  
Tel: +662 1054298 Fax: +662 0248256-9  
Email: mktg@krugerventasia.co.th  
Website: www.krugerfan.com

▶ **INDIA**

**KRUGER VENTILATION INDUSTRIES (INDIA) PVT. LTD.**  
Kruger Centre, Mumbai-Nasik Highway, Kalamgaon,  
Shahapur, Thane 421601, Maharashtra, India  
Tel: +91 9960558899, +91 97663 23739 Fax: -  
Email: sales@krugerventasia.co.th

▶ **KOREA**

**NEOMATE CO., LTD.**  
80, Seogeunnae-gil, Paltan-myeon, Hwaseong-si,  
Gyeonggi-do 18575, Korea  
Tel: +82-2-2679-2052 Fax: +82-2-2679-2174  
Email: y7890@neomate.co.kr

▶ **SINGAPORE**

**KRUGER ENGINEERING PTE. LTD.**  
2 Venture Drive #20-23, Vision Exchange,  
Singapore 608526.  
Tel: +65 68631191 Fax: +65 68631151  
Email: mktg@krugerfan.com

▶ **AUSTRALIA**

**S&P-KRUGER AUSTRALIA PTY. LTD.**  
2 Cunningham St, Moorebank N.S.W. 2170  
Tel: +612-98227747  
Fax: +612-98227757  
Email: info@sandpkruiger.com.au

▶ **INDONESIA**

**P.T. KRUGER VENTILATION INDONESIA.**  
Jl. Teuku Umar No. 20, Karawaci,  
Tangerang 15115, Indonesia  
Tel: +62 21-5512288  
Fax: +62 21-5513502  
Email: mktg@krugerventasia.co.th

▶ **MALAYSIA**

**KRUVENT INDUSTRIES (M) SDN. BHD.**  
Lot 850, Jalan Subang 7, Taman Perindustrian Subang,  
47500, Subang Jaya, Selangor D.E., Malaysia  
Tel: +603 80743399 Fax: +603 80743388  
Email: mktg@kruger.com.my

▶ **VIETNAM**

**KRUGER VENTILATION INDUSTRIES (VIETNAM) CO., LTD.**  
Lot A7, 2-4, C2 Road, Thanh Thanh Cong IZ,  
Trang Bang District, Tay Ninh Province, Vietnam  
Tel: +84-276 3585200/01/02 Fax: +84-276 3585199  
Email: mktg@krugervn.com

▶ **CHINA (Shanghai)**

**SHANGHAI KRUGER VENTILATION CO., LTD.**  
No. 500 Yuanguo Road, Anting, Jiading District,  
Shanghai 201814, P.R. China  
Tel: +86 21-69573266 Fax: +86 21-69573296  
Email: ksh@krugerfan.com.cn  
Website: www.krugerfan.com.cn

▶ **CHINA (Tianjin)**

**TIANJIN KRUGER VENTILATION CO., LTD.**  
Jingjin Science and Technology Park,  
Wuqing District, Tianjin 301700, P.R. China  
Tel: +86 22-22143480 Fax: +86 22-22143482  
Email: ktj@krugerfan.com.cn

▶ **CHINA (Guangzhou)**

**GUANGZHOU KRUGER VENTILATION CO., LTD.**  
No. 9 Huahui Road, Huashan Town,  
Huadu District Guangzhou 510880, P.R. China  
Tel: +86 20-66356635 Fax: +86 20-86786001/86786500  
Email: kgv@krugerfan.com.cn

▶ **CHINA (Wuhan)**

**WUHAN KRUGER VENTILATION CO., LTD.**  
No. 805 Huian Avenue, Dongxihu District Wuhan,  
Hubei 430040, P.R. China  
Tel: +86 27- 83248840  
Fax: +86 27- 83261886  
Email: kwv@krugerfan.com.cn

▶ **HONG KONG**

**KRUGER VENTILATION (HONG KONG) LIMITED.**  
Flat E, 8/F, Yeung Yiu Chung (No.8) Industrial Building,  
20 Wang Hoi Road, Kowloon Bay, Kowloon, Hong Kong  
Tel: +852 22469182 Fax: +852 22469187  
Email: info@kruger.com.hk

▶ **TAIPEI**

**KRUGER VENTILATION (TAIWAN) CO., LTD.**  
No. 157, Ping-an Rd, Hengfeng Village,  
Dayuan Shiang Taoyuan County 337, Taiwan  
Tel: +886 3-3859119 Fax: +886 3-3859118  
Email: sales@krugertwn.com.tw

▶ **PHILIPPINES**

**KRUGER M & E INDUSTRIES CORP.**  
B3 Welborne Industrial Park, Bancal, Carmona,  
Cavite, Philippines 4116  
Tel: +63-917-561-9088, +63-917-596-7288,  
+63-917-712-8438, +63-917-306-8288 Fax: -  
Email: mktg.ph@krugerfan.com



**KRUGER**

**Kruger Ventilation Industries Asia Co., Ltd.**

30/159 Moo 1, Sinsakorn Industrial Estate  
Chetsadawithi Road, Khok Kham Mueng,  
Samuthsakorn 74000, Thailand  
Tel. +662 1054298 - Fax. +662 0248256-9  
Website: [www.krugerfan.com](http://www.krugerfan.com)  
**CAT040.E1.ED2 May 2026**

**A member of**

Soler&Palau  Ventilation Group